

5276412COM Kitchen Cart

Ameriwood
HOME

Date of Purchase ___ / ___ / ___
Lot Number:

B345276412COM0

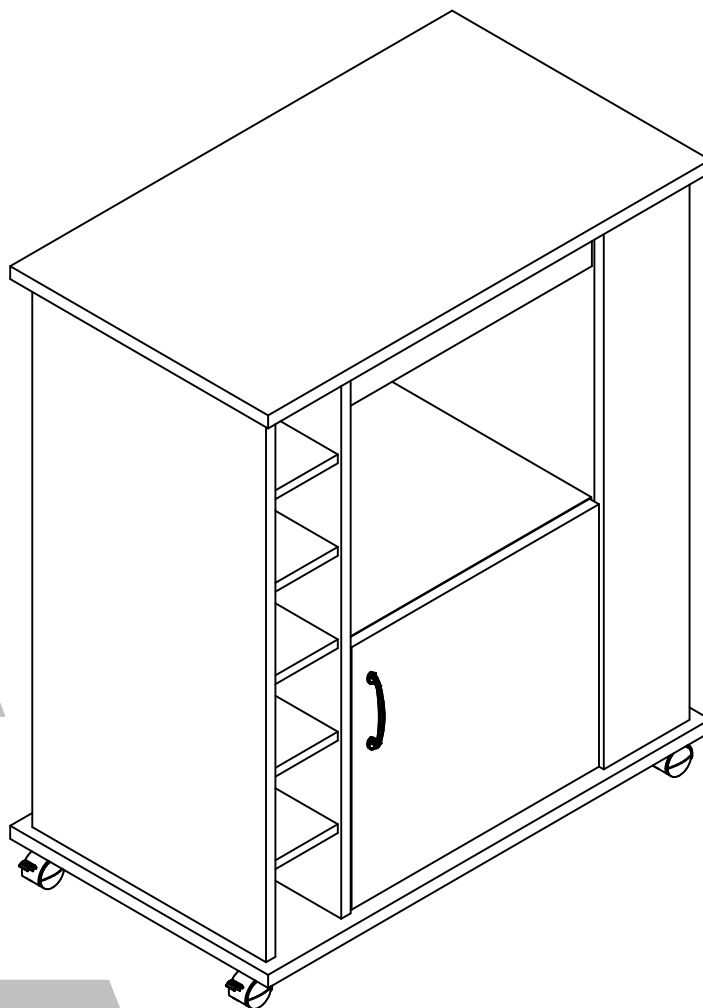

THIS INSTRUCTION BOOKLET CONTAINS **IMPORTANT** SAFETY INFORMATION. PLEASE READ AND KEEP FOR FUTURE REFERENCE.

Do Not Return This Product!

Contact our customer service team for help first.

Call: 1-800-489-3351 (toll free)

Monday-Friday 9am - 5pm CST

Visit: www.ameriwoodhome.com



WARNING

- Unit can tip over causing severe injury or death.
- Anchor unit to stud in wall (if instructed to).
- Do Not allow children to climb on unit.
- Put heavy items on lower shelves or drawers.



Follow Ameriwood Home



Contact Us!

Do NOT return this product!

Contact our friendly customer service team first for help.

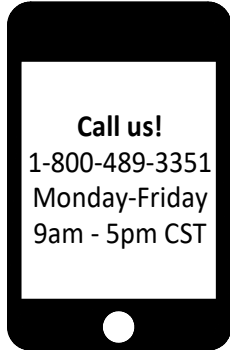

Visit ameriwoodhome.com to view the limited warranty valid in the U.S. and Canada.

Assembly Tips



Helpful Hints

PEOPLE NEEDED FOR ASSEMBLY: 2

ESTIMATED ASSEMBLY TIME: 1 HOUR

- Open your item in the area you plan to keep it to avoid excessive heavy lifting.
- Identify, sort and count the parts before attempting assembly.
- Compression dowels are lightly tapped in with a hammer.
- Slides are labeled with a **R** (right) and **L** (left) for proper placement.
- Make sure to always face the point on the top of the Cam Lock towards the outer edge.
- Use all the nails provided for the back panel and spread them out equally.
- Back panel must be used to make sure your unit is sturdy.
- Do NOT use harsh chemicals or abrasive cleaners on this item.
- Never push, pull, or drag your furniture.



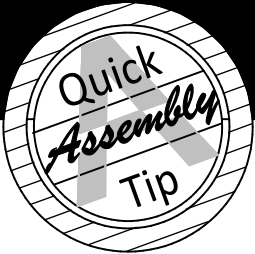

Before You Start

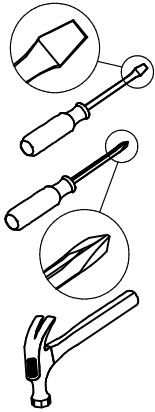

- ✓ Read through each step carefully and follow the proper order
- ✓ Separate and count all your parts and hardware
- ✓ Give yourself enough room for the assembly process
- ✓ Have the following tools: Flat Head Screwdriver, #2 Phillips Head Screwdriver and Hammer
- ✓ Caution: If using a power drill or power screwdriver for screwing, please be aware to slow down and stop when screw is tight. Failure to do so may result in stripping the screw.

Cam Lock Fastening System

This Cam Lock Fastening System will be used throughout the assembly process.

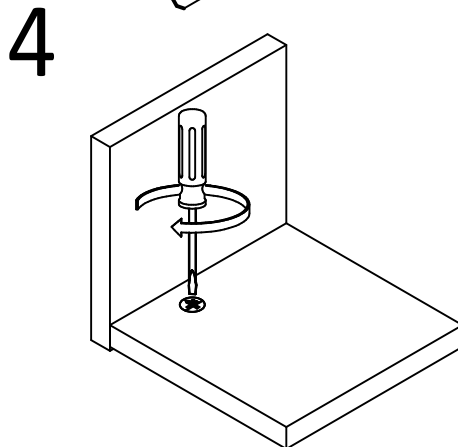
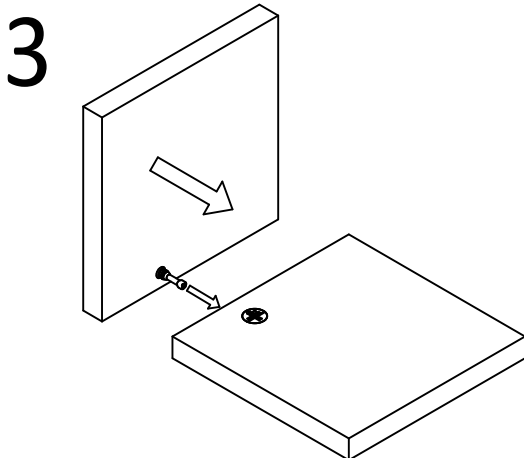
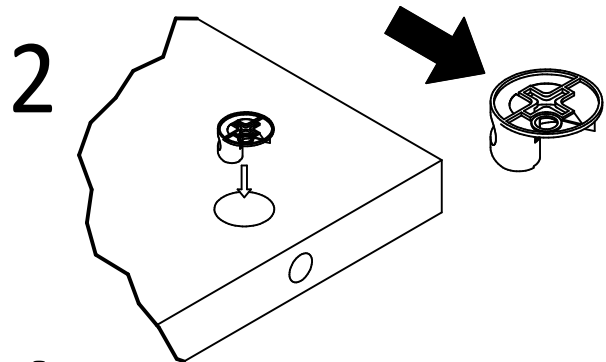
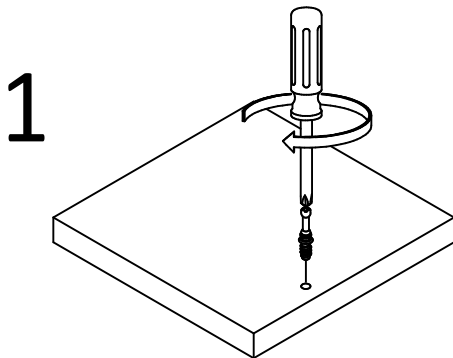

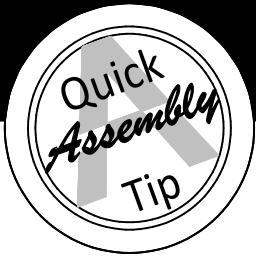

Before You Start

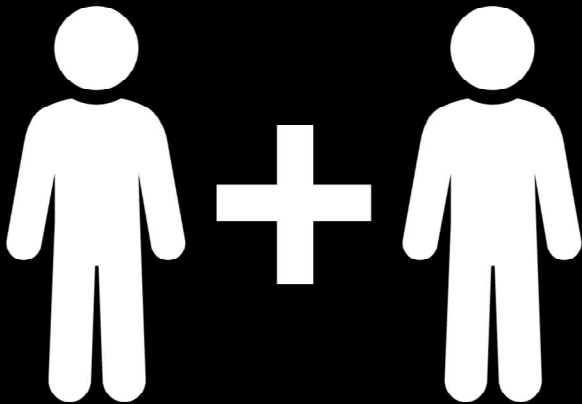

2 PEOPLE NEEDED FOR ASSEMBLY

**2 PERSONAS NECESITADAS
PARA LA ASAMBLEA**

**2 PERSONNES NÉCESSAIRES
POUR L'ASSEMBLAGE**

CAUTION: Failure to use 2 people for assembly could result in unit damage or personal injury.

PRECAUCIÓN: Si no se utilizan 2 personas para el ensamblaje, se pueden producir daños en la unidad o lesiones personales.

ATTENTION: Échec d'utiliser 2 personnes pour l'assemblage peut causer du dommage au meuble ou causer des blessures.

Board Identification

Not actual size

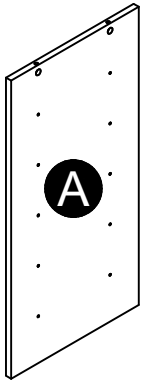

Left Panel
35276412010

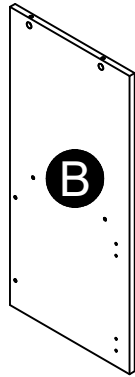

Right Panel
35276412020

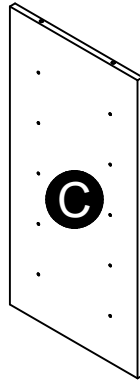

Partition
35276412030



Left Back Panel
35276412040



Right Front Panel
35276412050

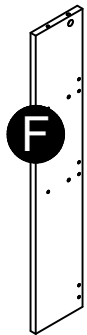

Right Back Panel
35276412060

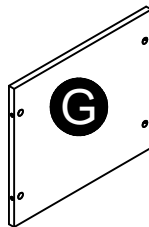

Center Back Panel
35276412070

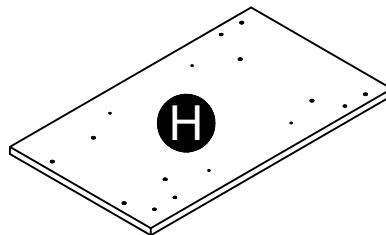

Top
35276412080

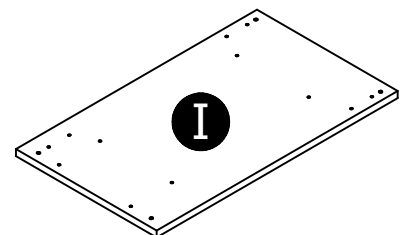

Bottom
35276412090

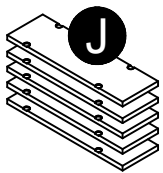

Left Shelf (x5)
35276412100

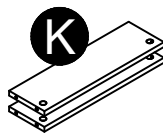

Right Shelf (x2)
35276412110

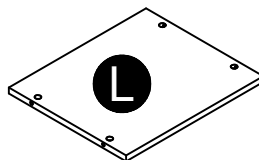

Center Shelf
35276412120

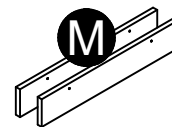

Center Rail (x2)
35276412130

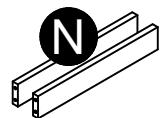

Right Rail (x2)
35276412140

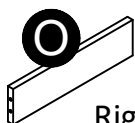

Right Bottom Rail
35276412150

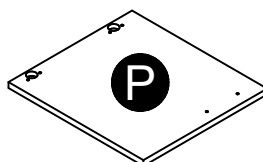

Door
35276412160

Board Identification

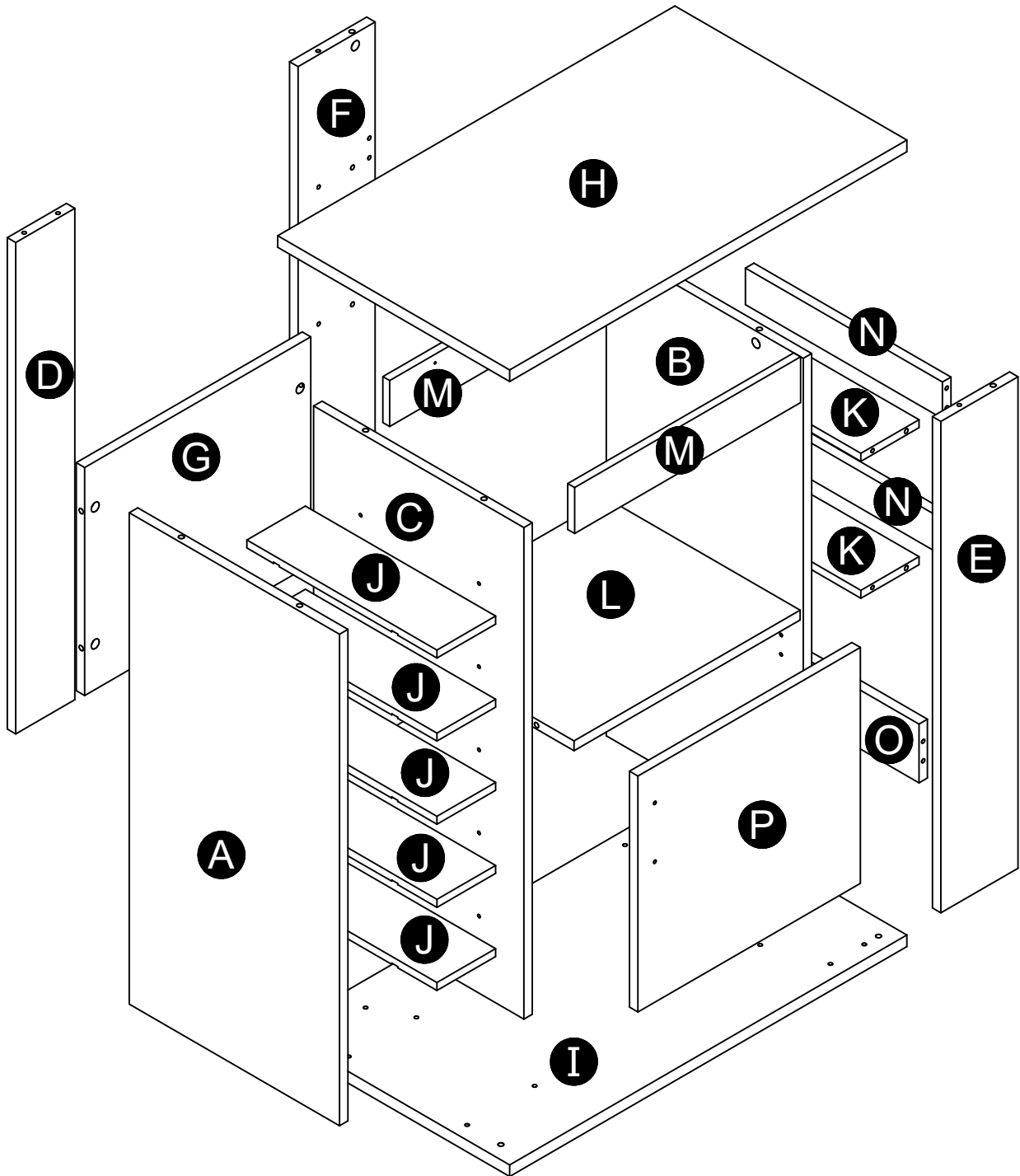

Part List

Actual Size

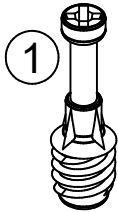

(x20)
#A22610
cam bolt



(x20)
#A22620
cam lock

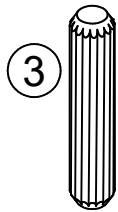

(x20)
#A21660
wood dowel

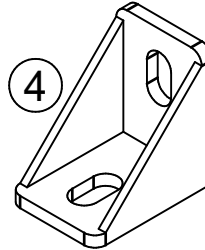

(x4)
#A53510
angle bracket



(x8)
#A12120
7/16" pan head



(x20)
#A80250
shelf support

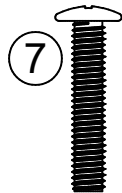

(x2)
#A17400
7/8" bolt

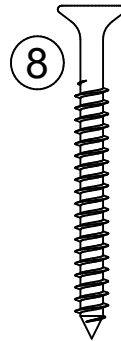

(x12)
#A13410
1-3/4" flat head

Not Actual Size

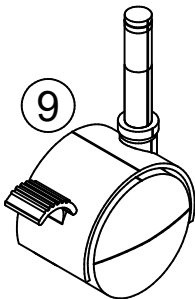

(x4)
#A42590
caster

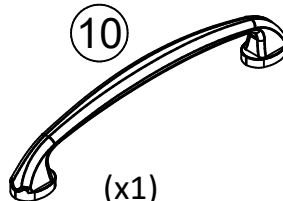

(x1)
#A51925
handle

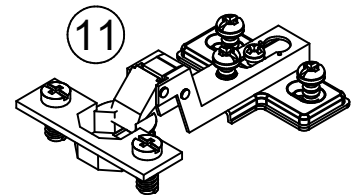

(x2)
#A65640
hinge

STEP 1

2



(x2)
#A22620

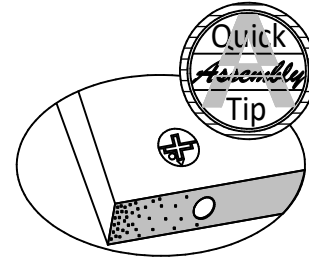

Proper orientation of CAM LOCK

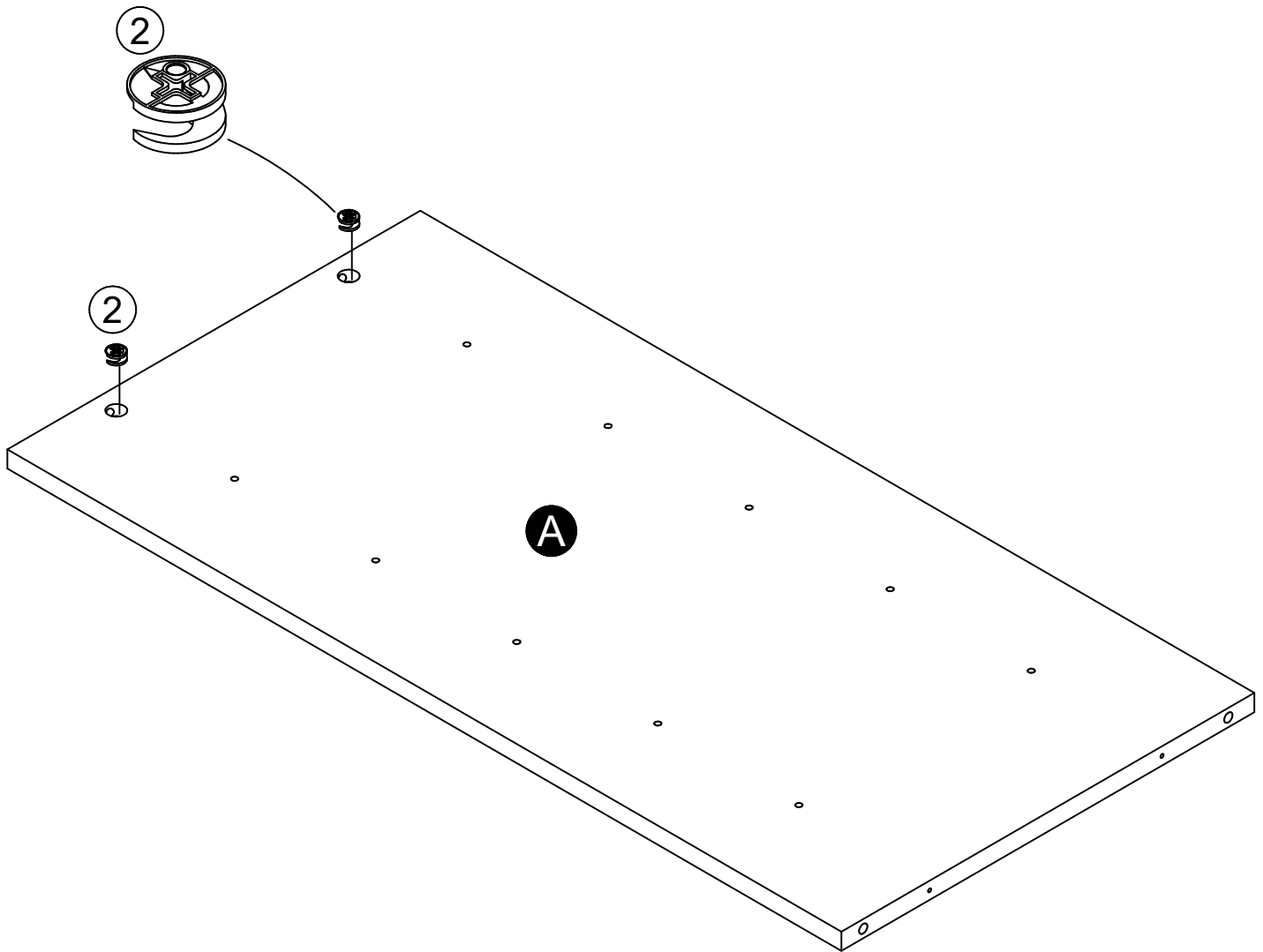

STEP 2

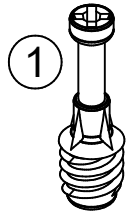
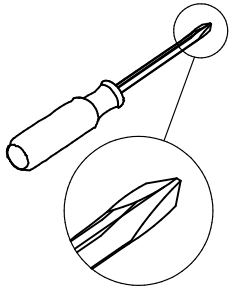

(x4)
#A22610



(x2)
#A22620

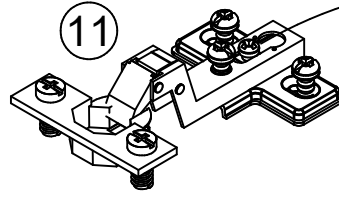

(x2)
#A65640

Loosen to separate

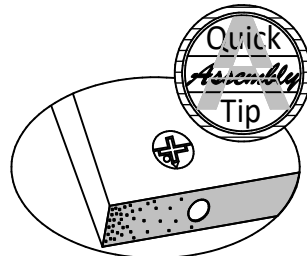

Proper orientation of CAM LOCK

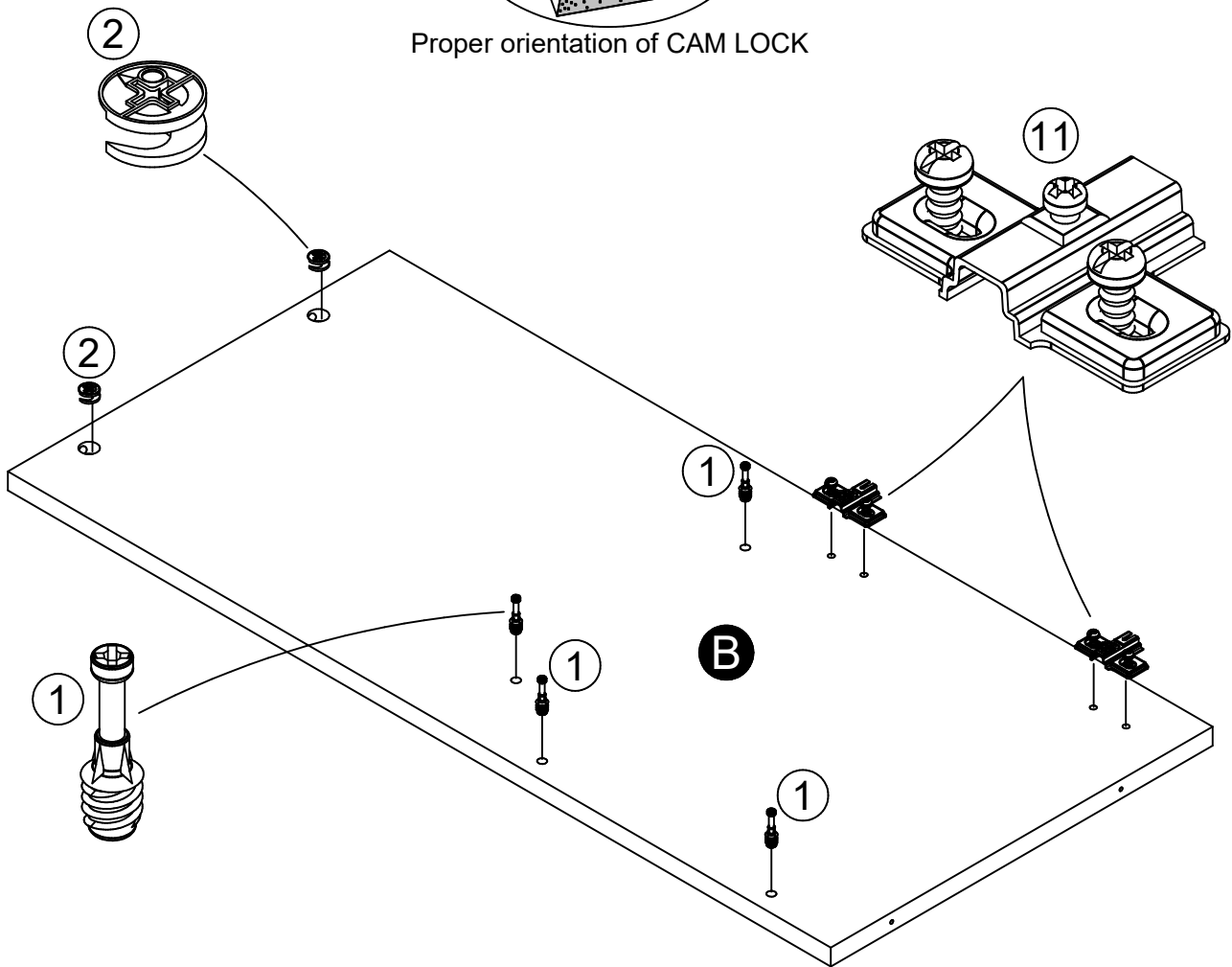
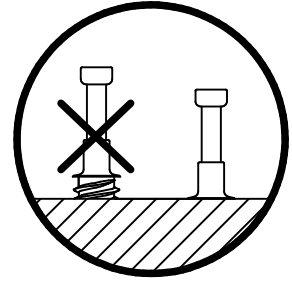

STEP 3

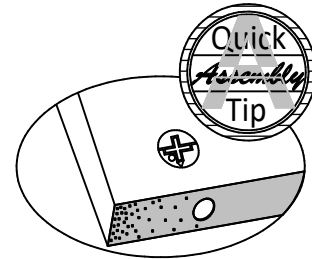
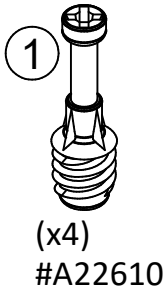
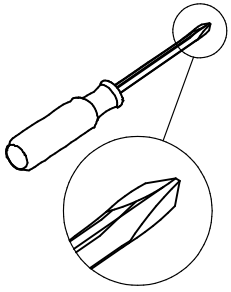

Proper orientation of CAM LOCK

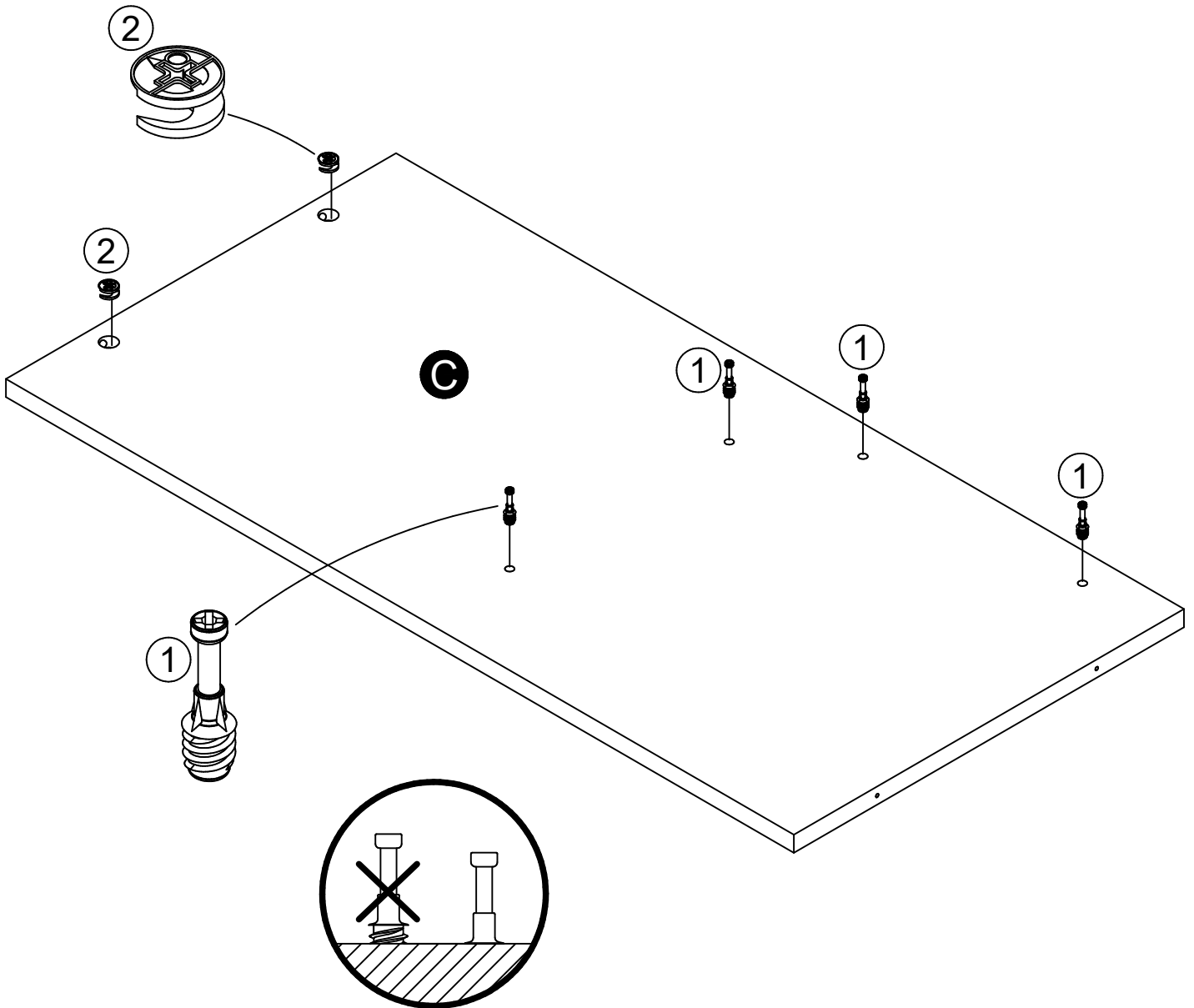

STEP 4

2
(x8)
#A22620

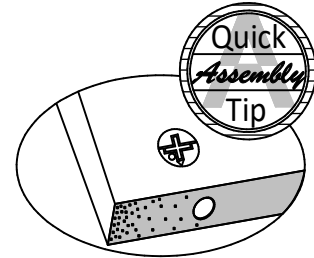

Proper orientation of CAM LOCK

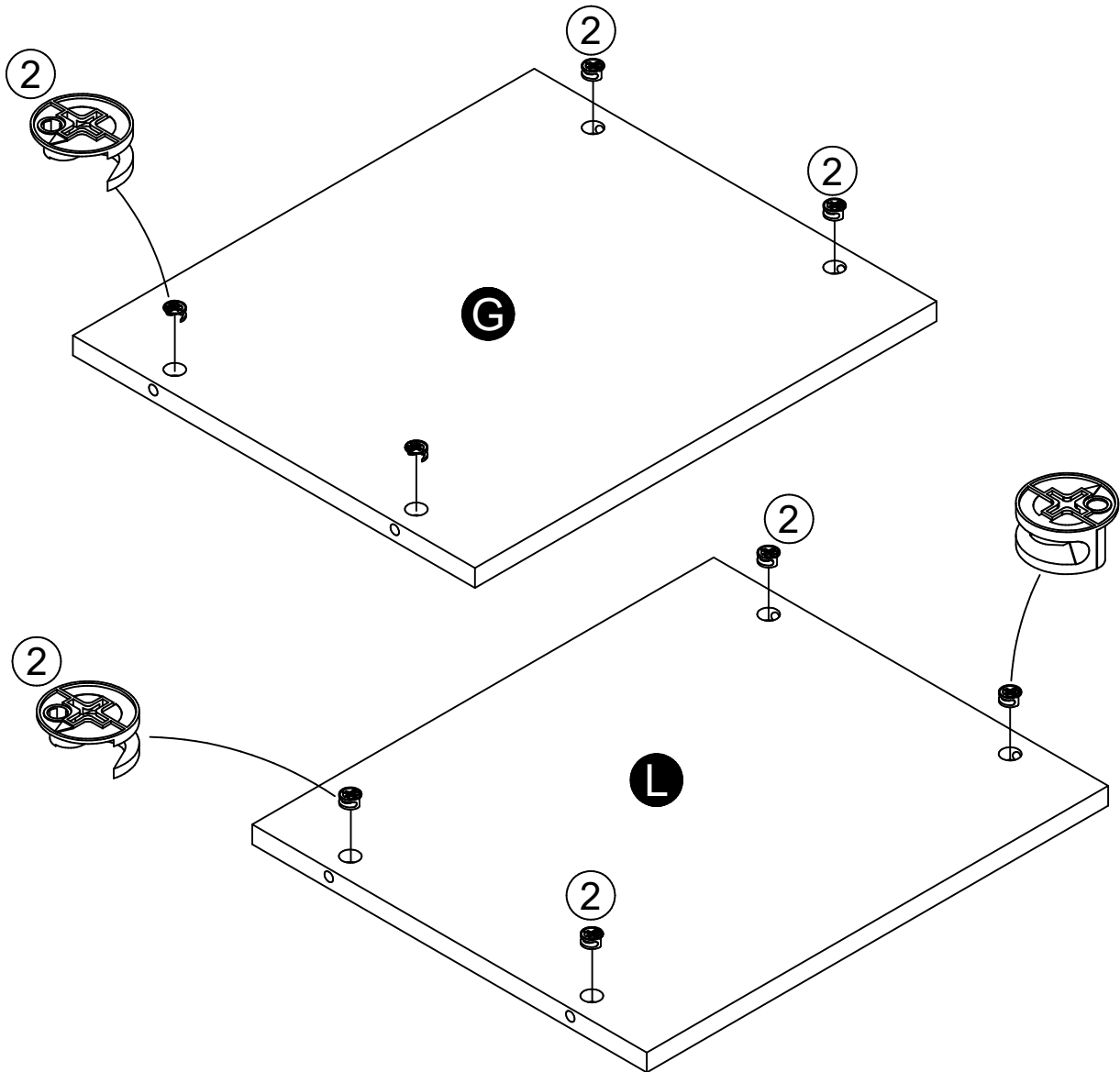

STEP 5

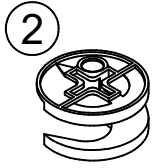

(x4)
#A22620

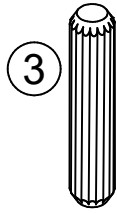

(x16)
#A21660

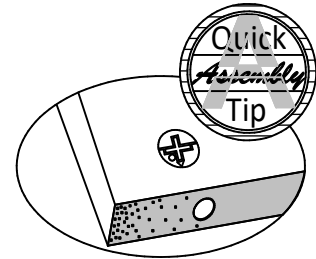

Proper orientation of CAM LOCK

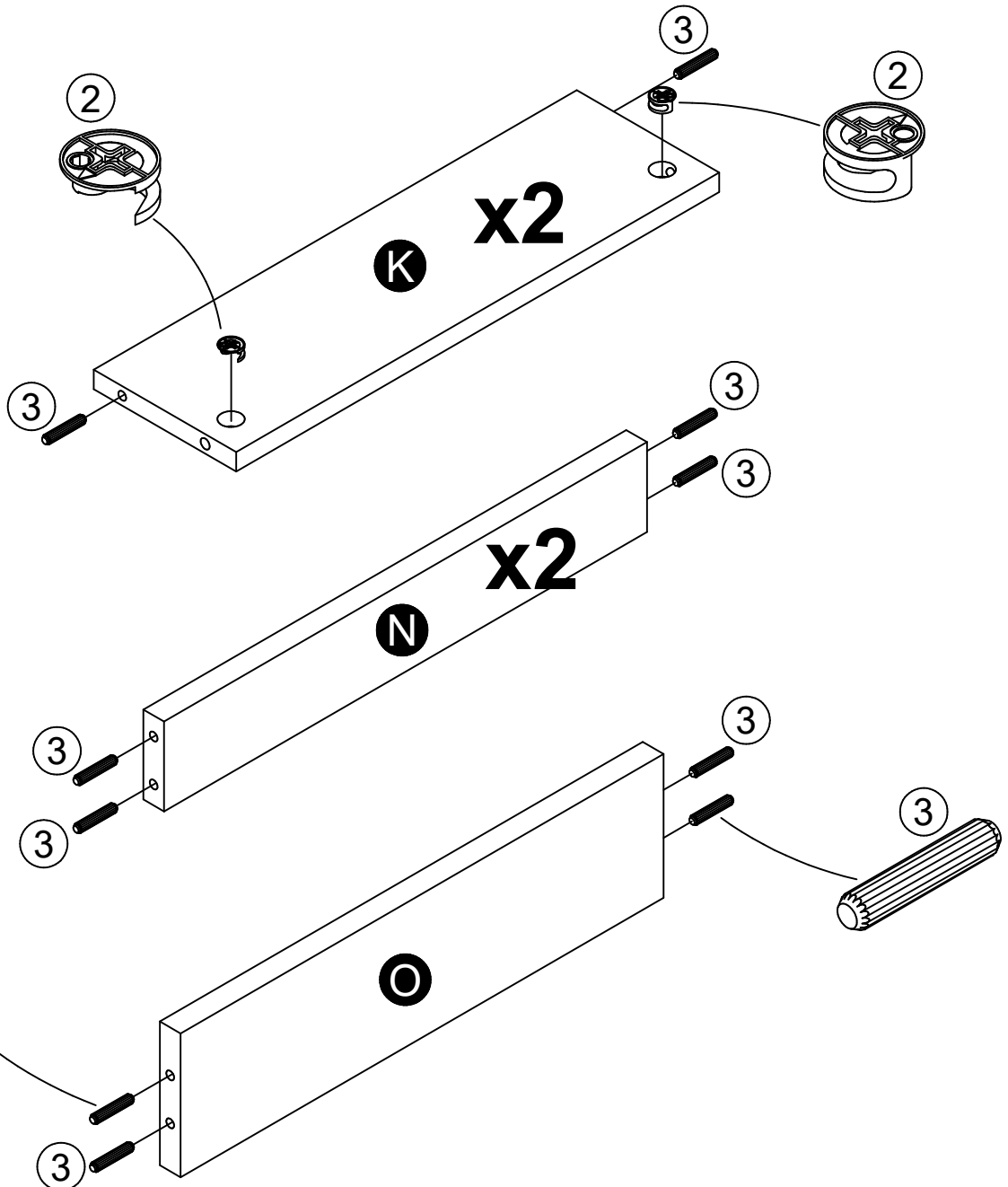

STEP 6

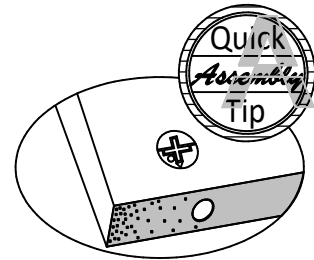
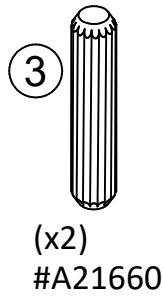
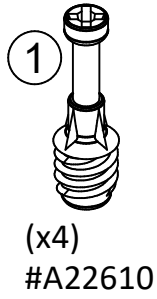
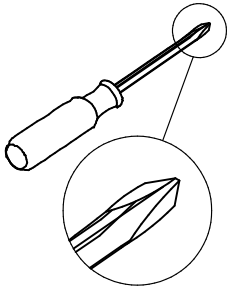

Proper orientation of CAM LOCK

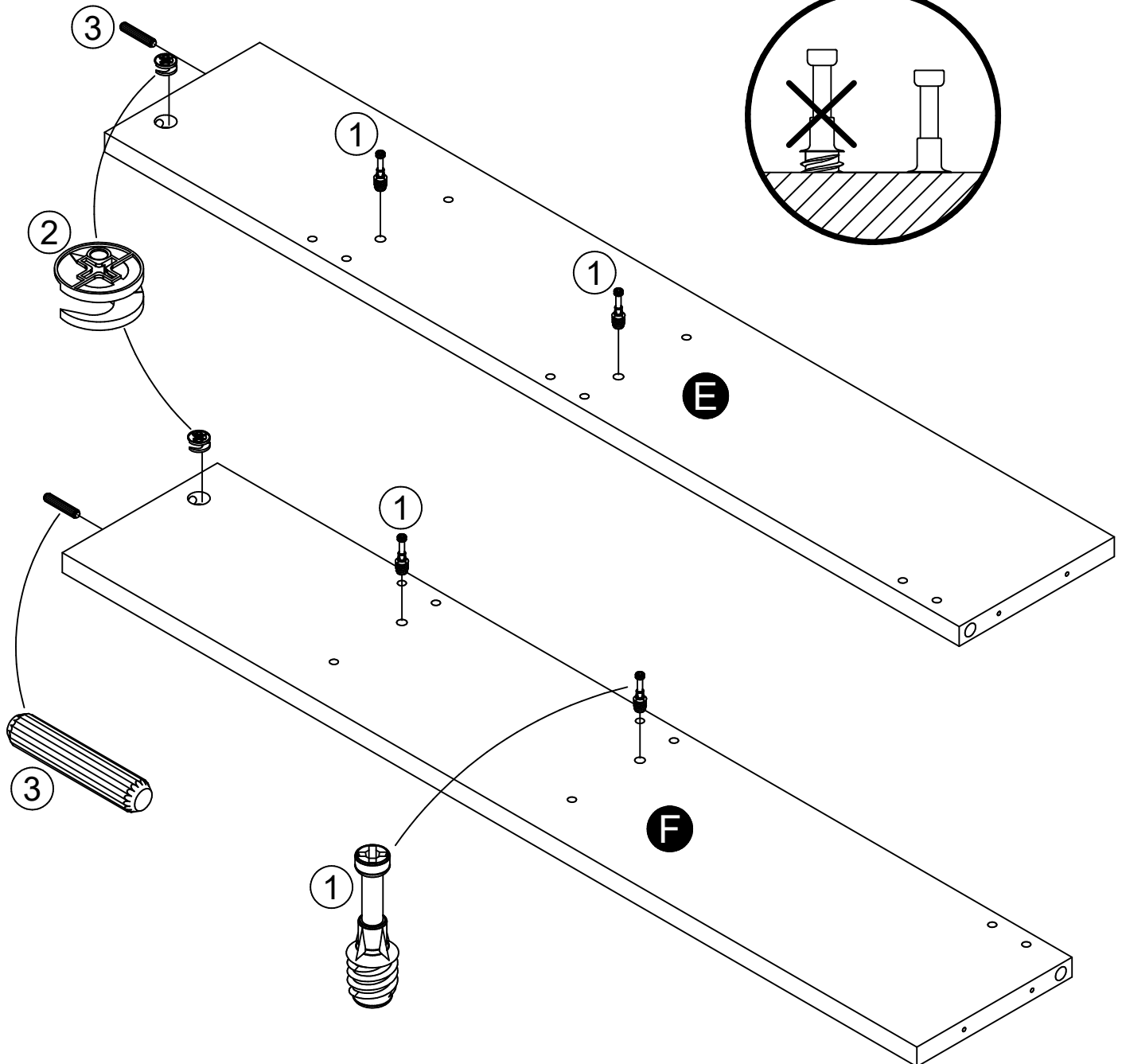
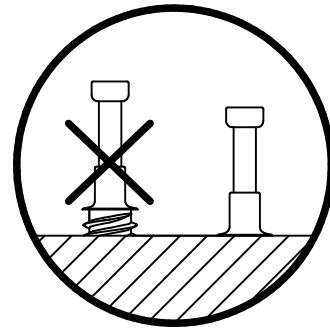

STEP 7

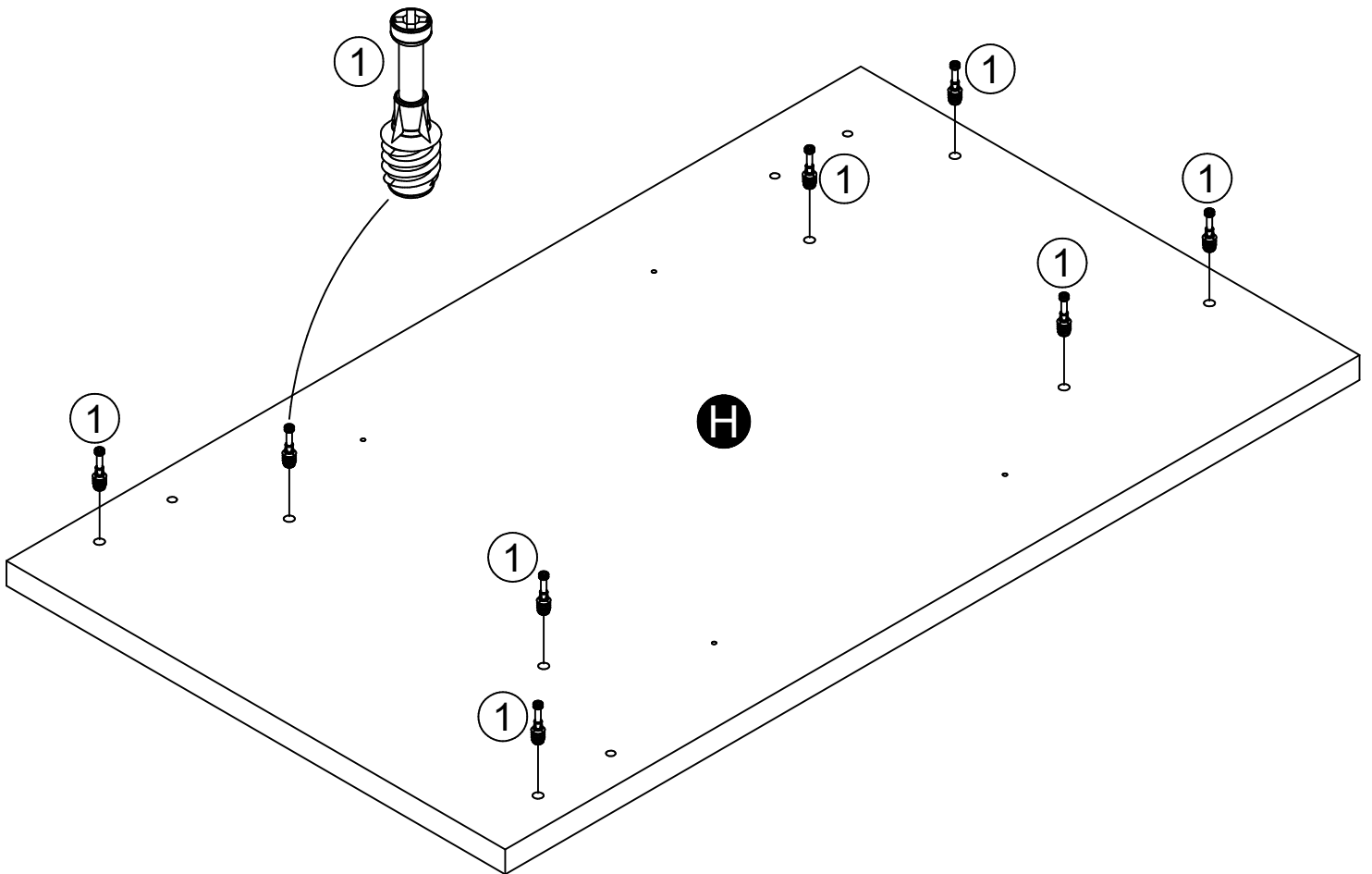
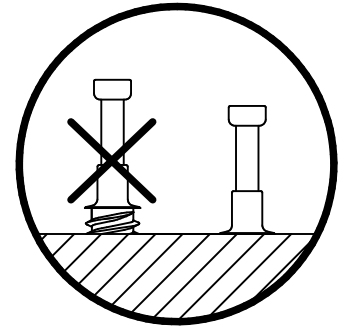
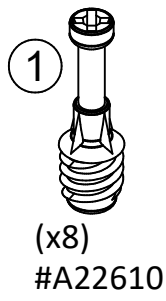
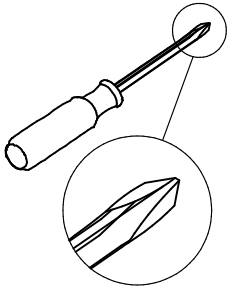

STEP 8

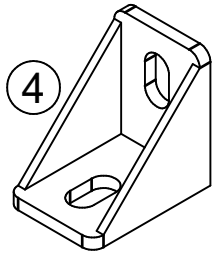
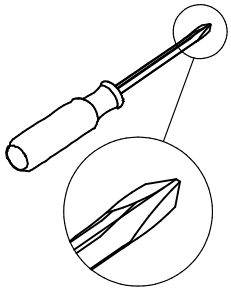

(x4)
#A53510



(x8)
#A12120

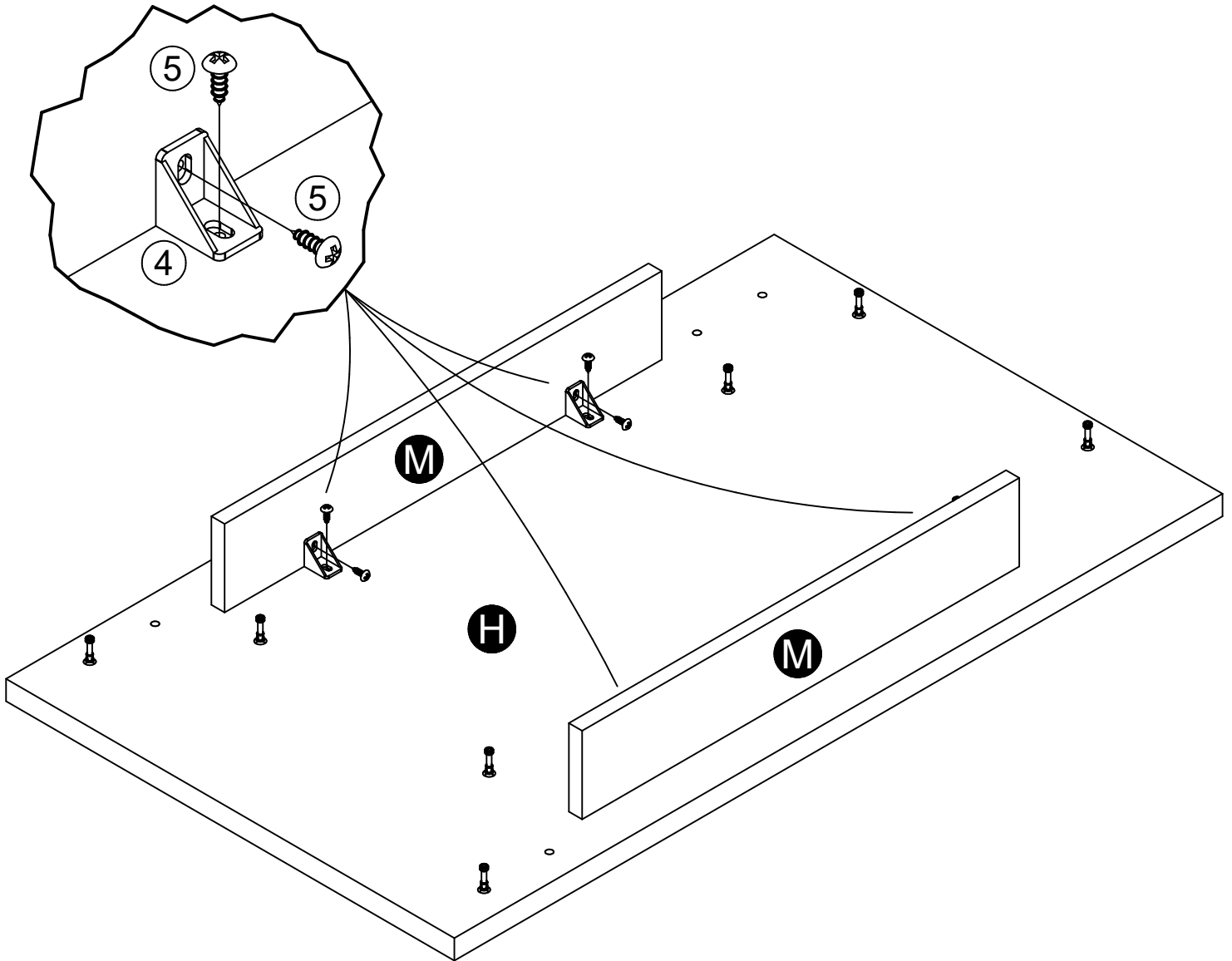

STEP 9

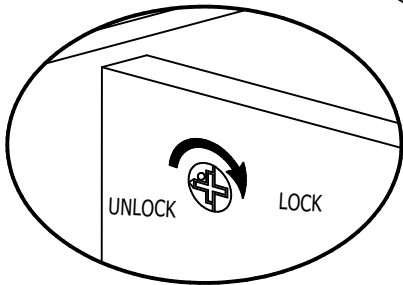
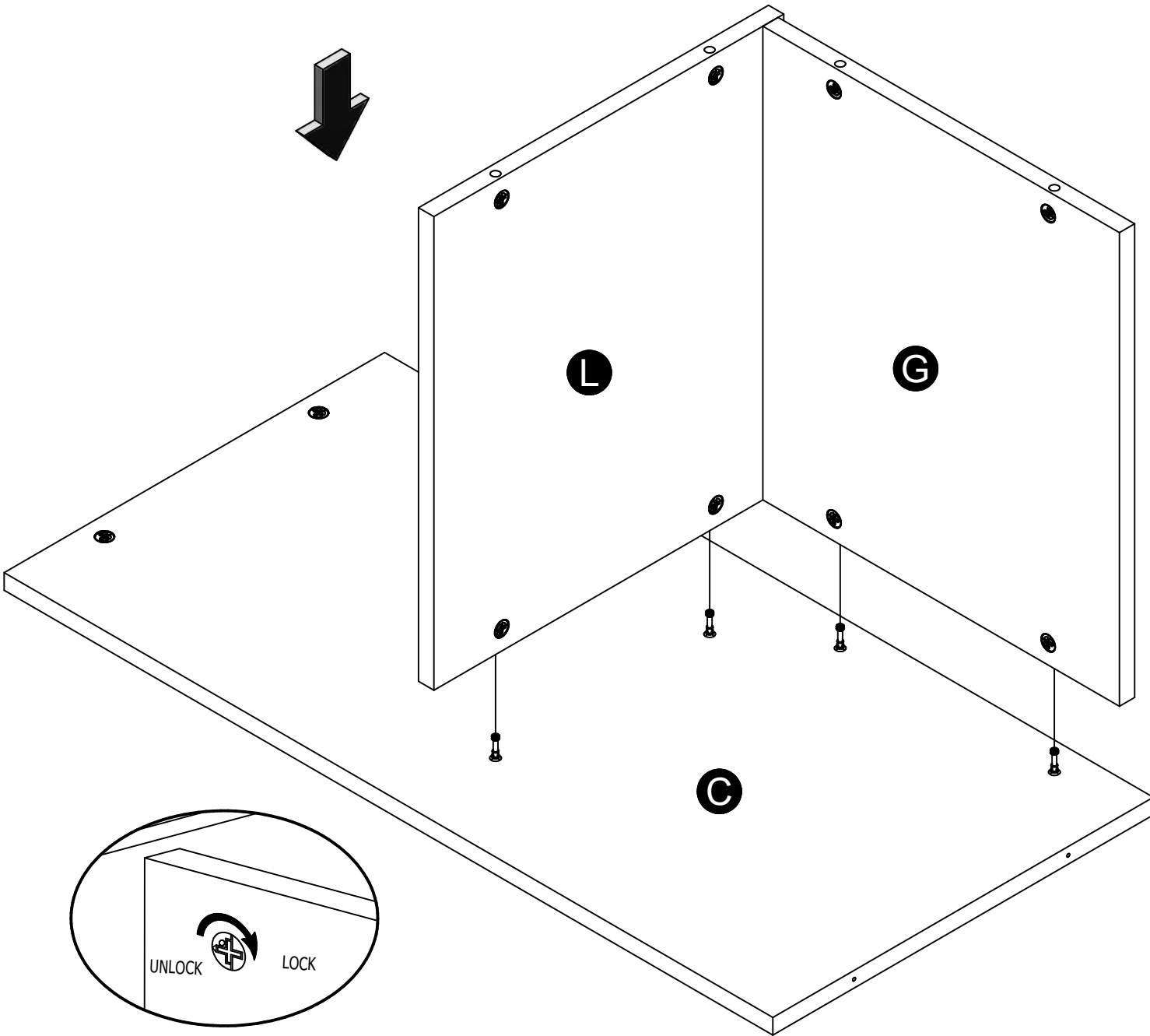
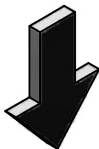
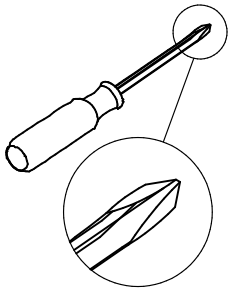

STEP 10

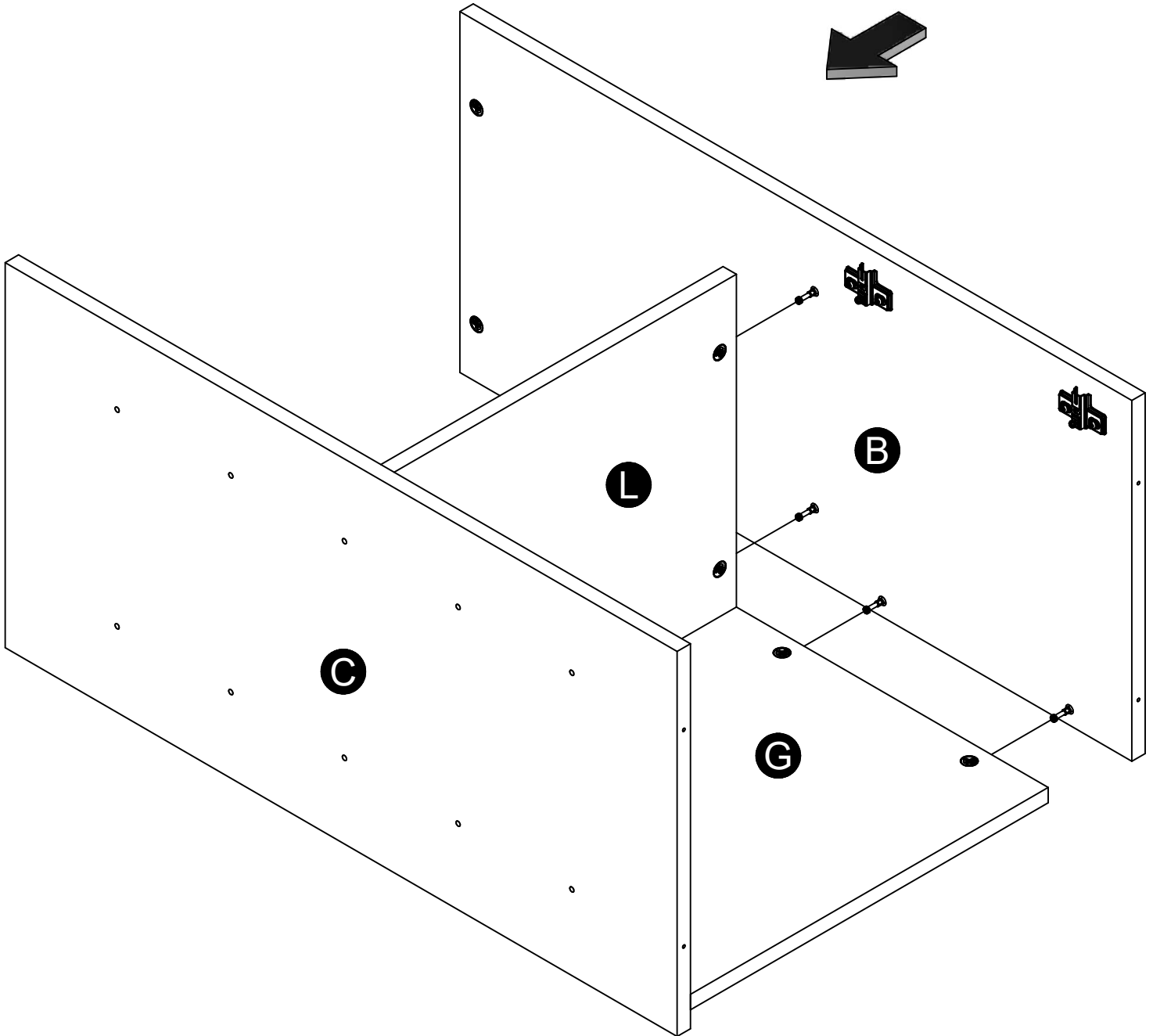
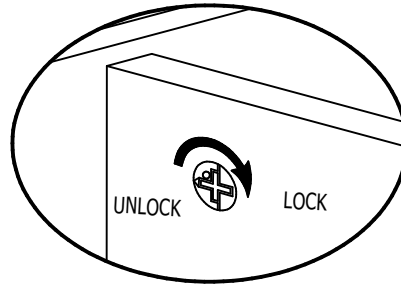
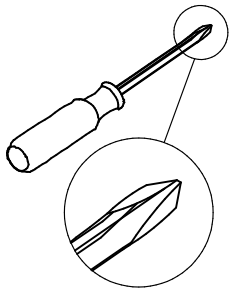

STEP 11

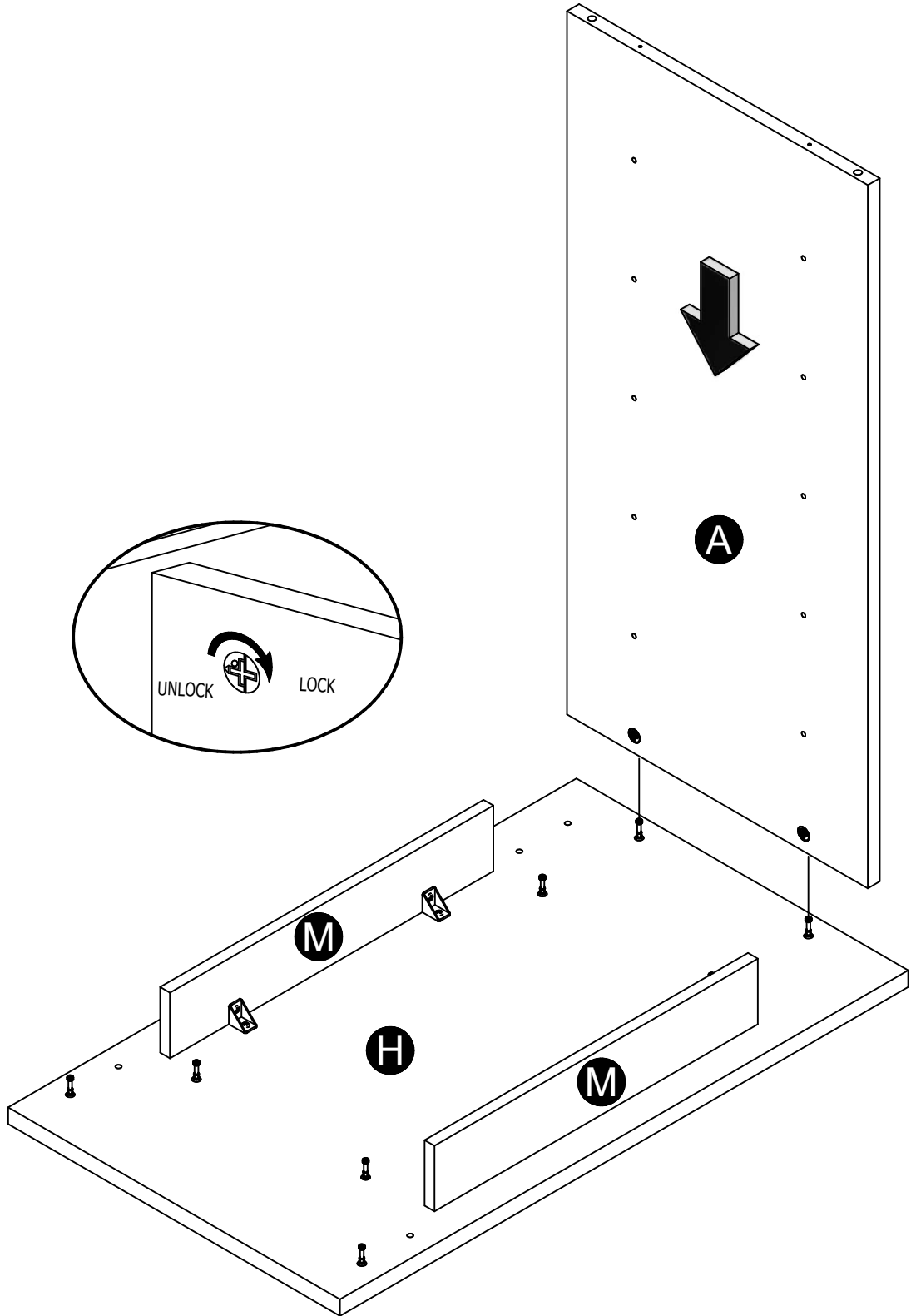
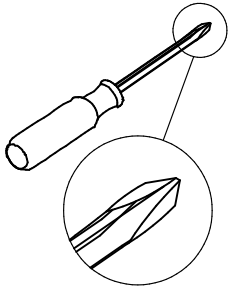

STEP 12

Note: The center rails (M) will be positioned between the right panel (B) and partitin (C).

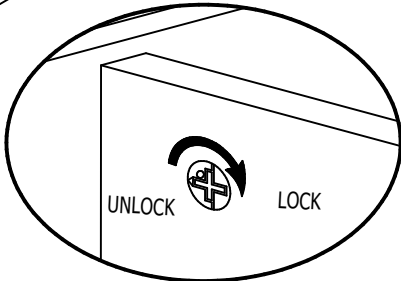
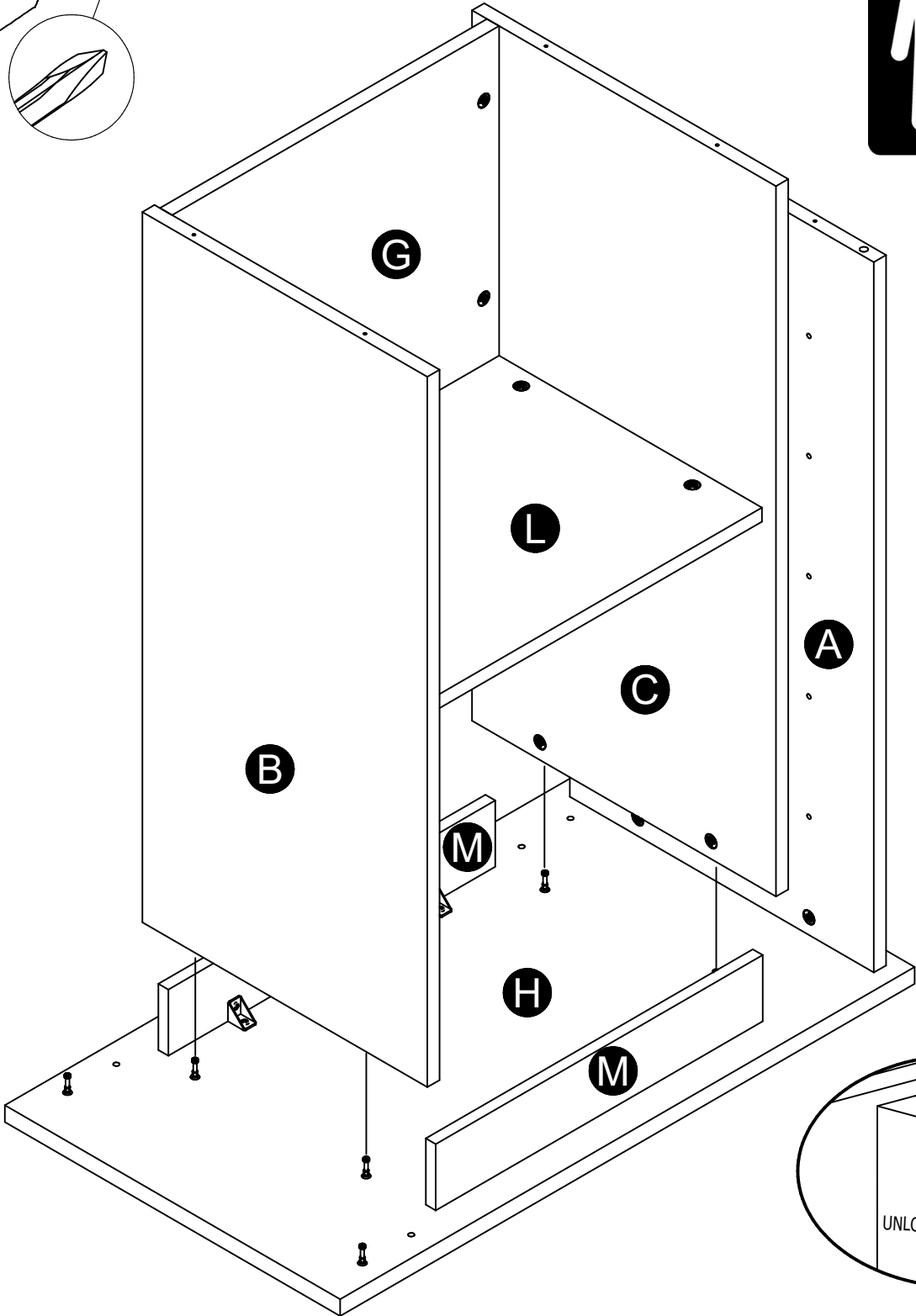
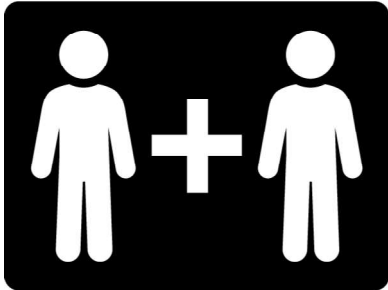
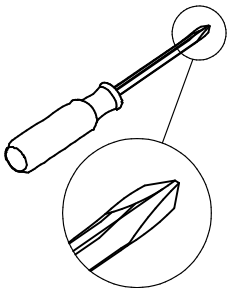

STEP 13

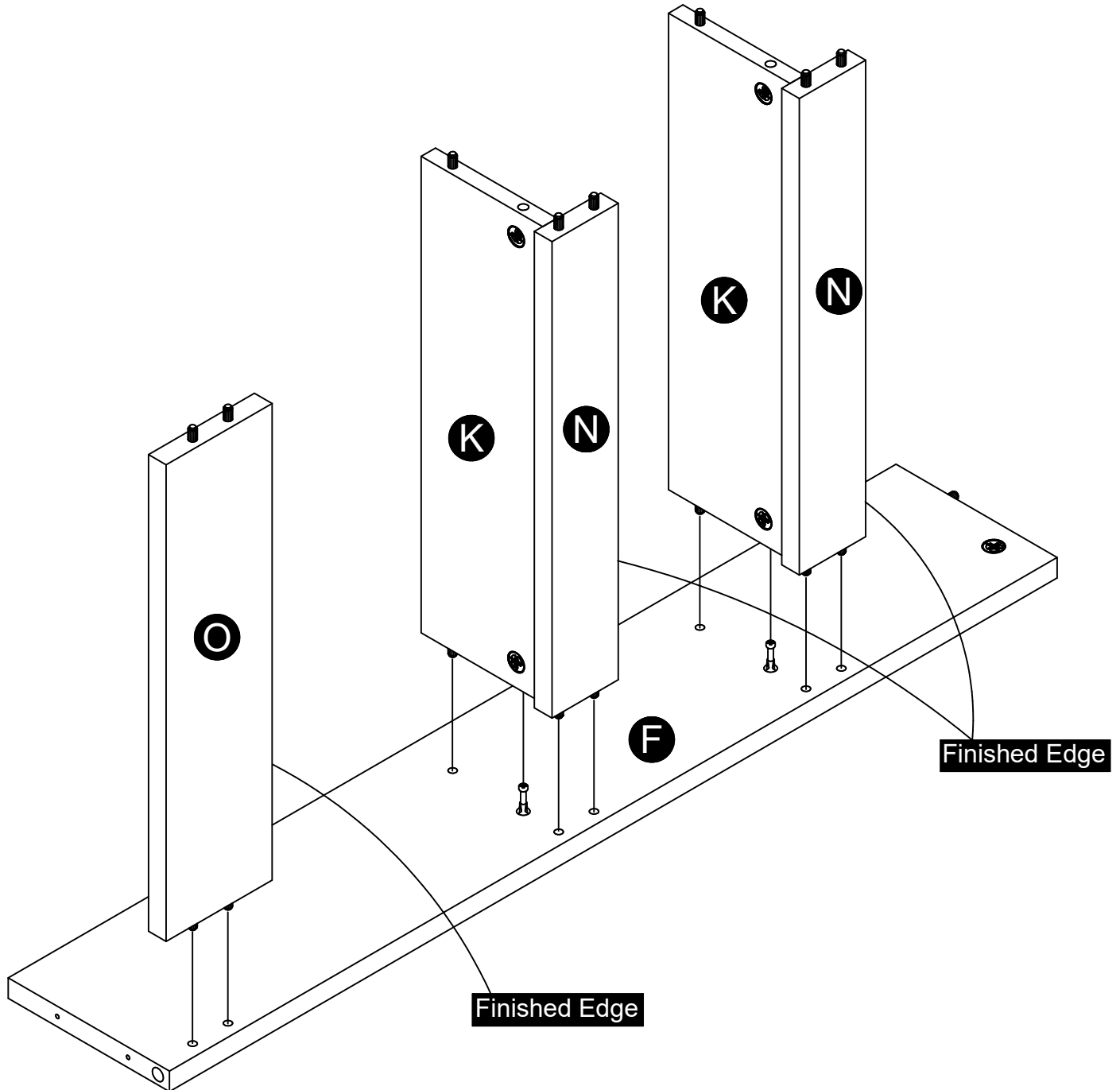
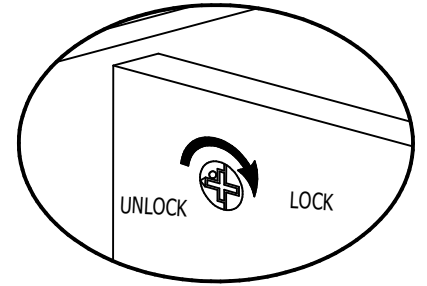
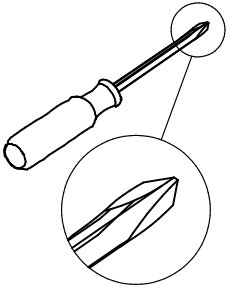

STEP 14

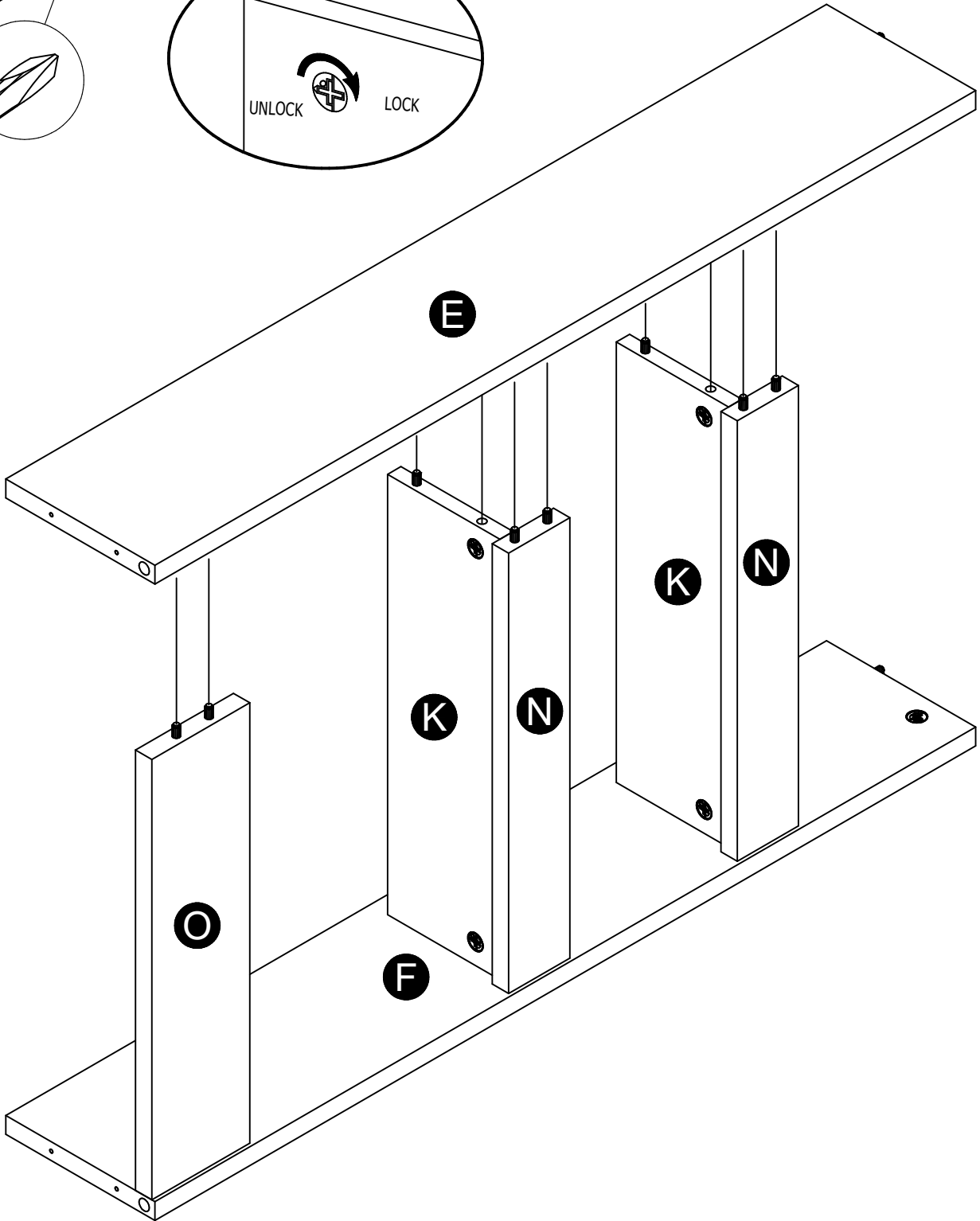
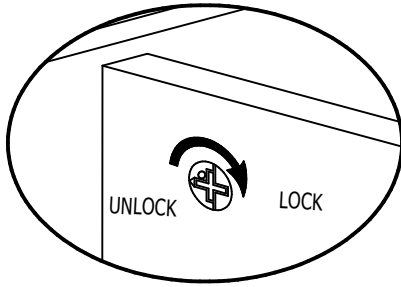
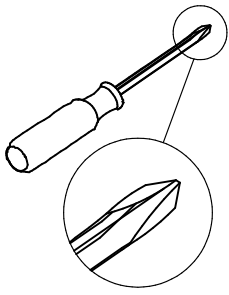

STEP 15

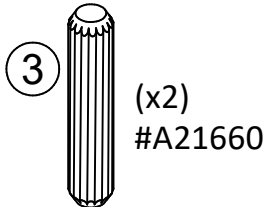

Insert wood dowels (3) into the larger end holes as shown. Please note, panels E & F will cover the front and back edges of the right panel (B) when installing.

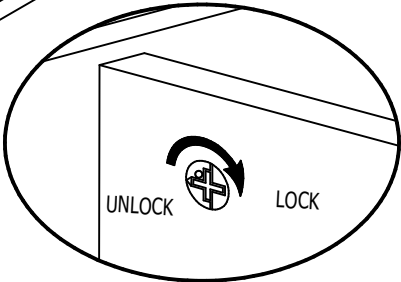
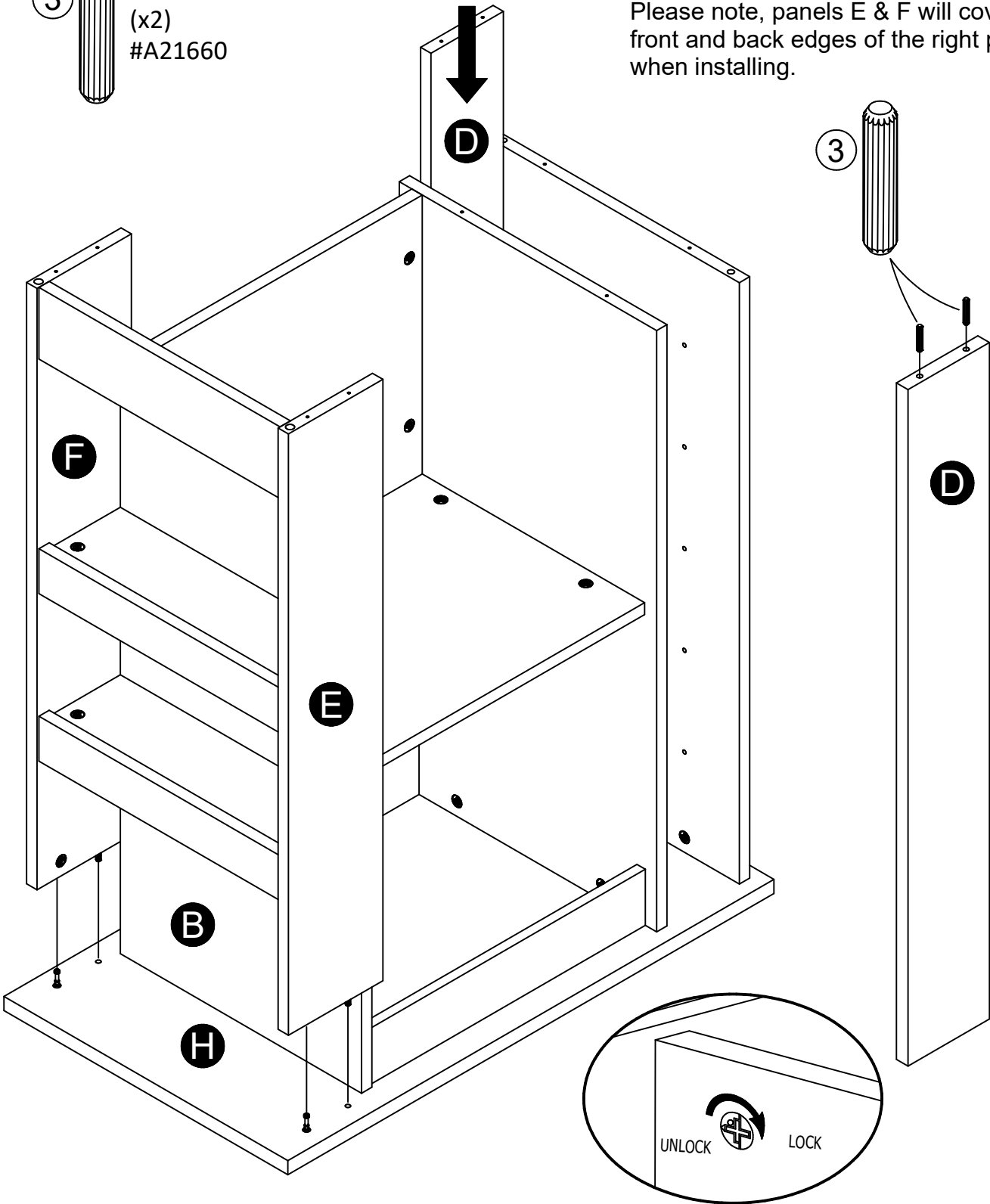

STEP 16

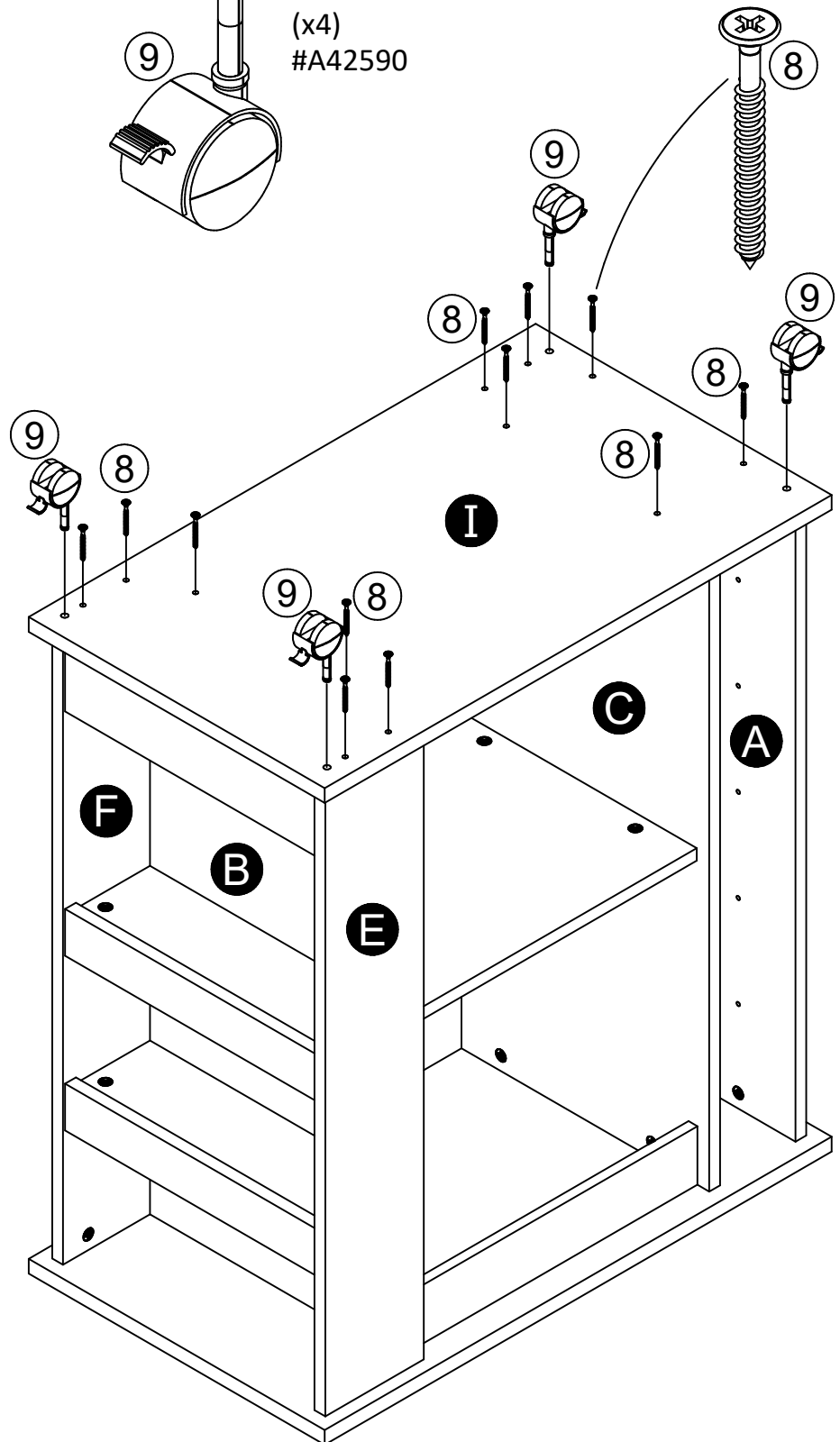
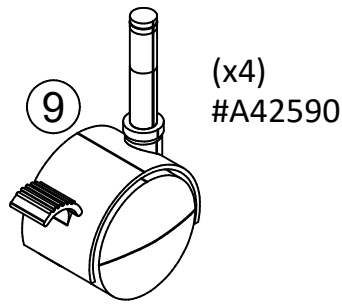
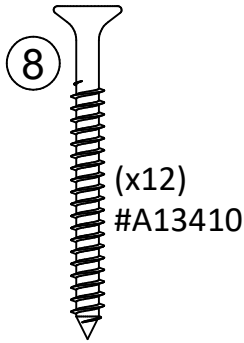
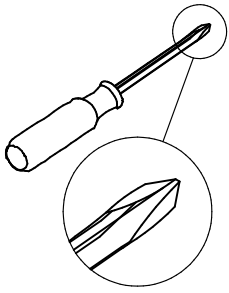

Insert casters (9) first.

Insert the casters (9) into the larger holes as shown and press in. The caster stem will insert into the bottom shelf holes and while pressing in will insert into end holes in panels (A, E & F).
Using screws (6), attach the bottom (I) as shown.

STEP 17

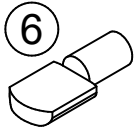

(x20)
#A80250

Insert the shelf supports (8) into the holes in the left panel (A) and partition (C) and set the left shelves (J) in place.

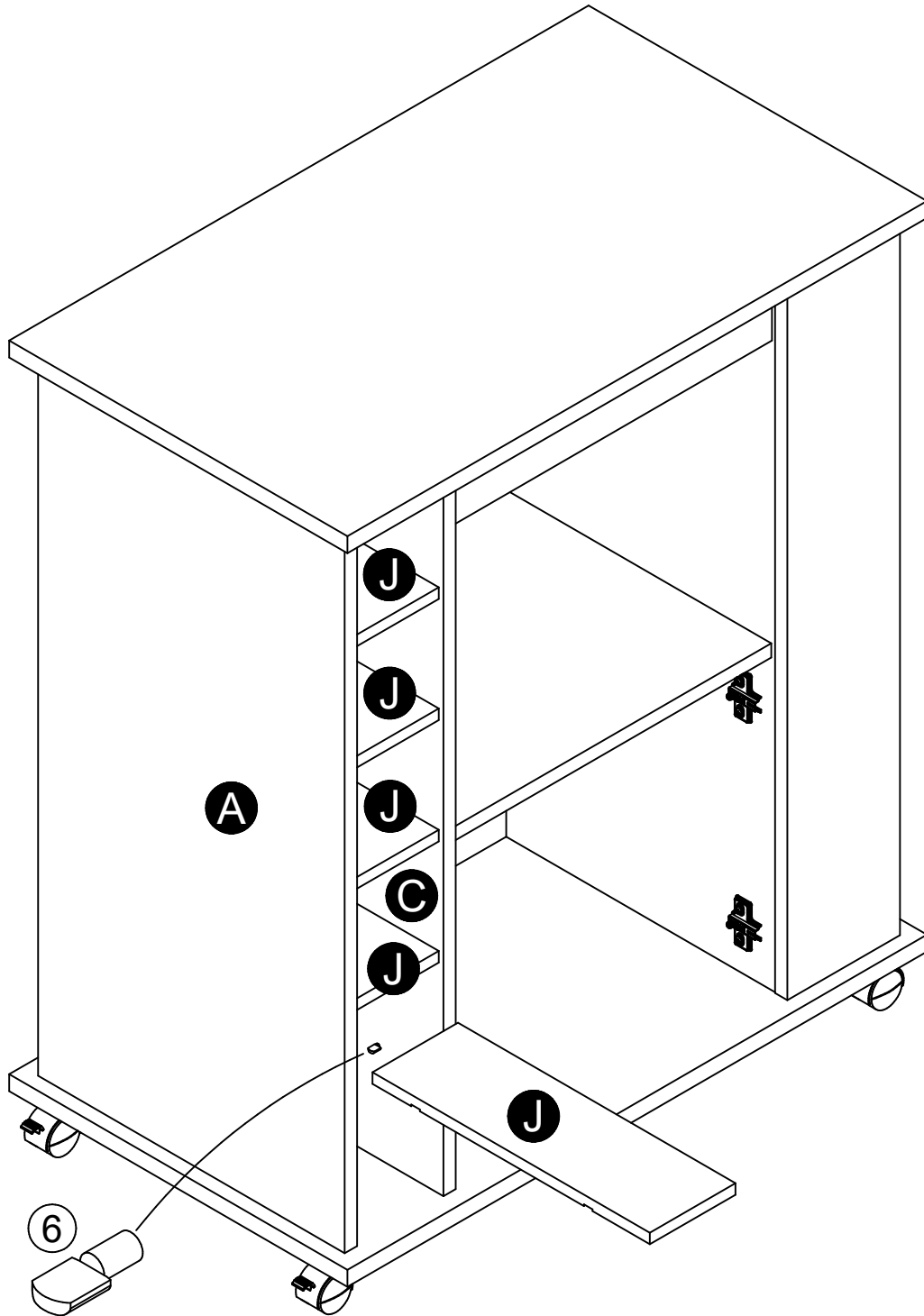

STEP 18

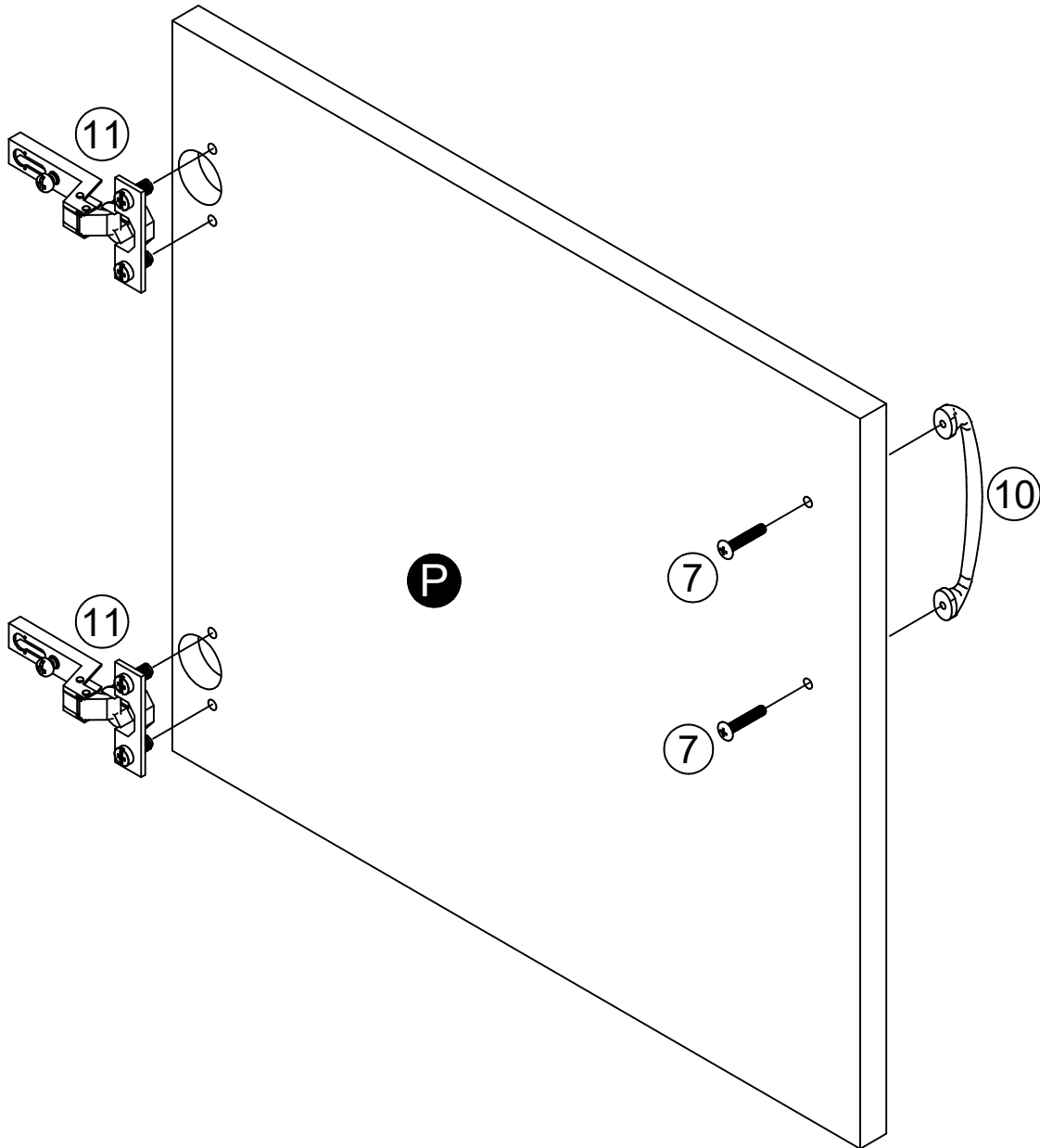
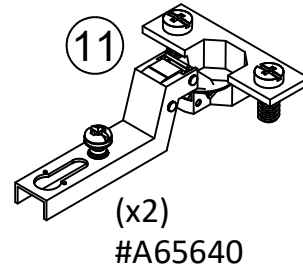
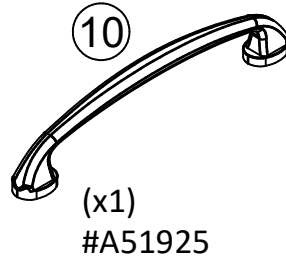
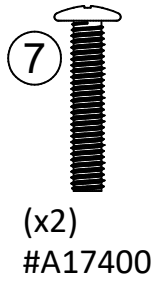
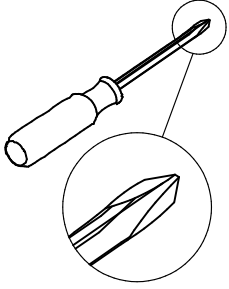

STEP 19

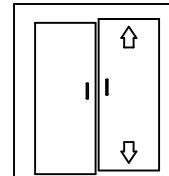
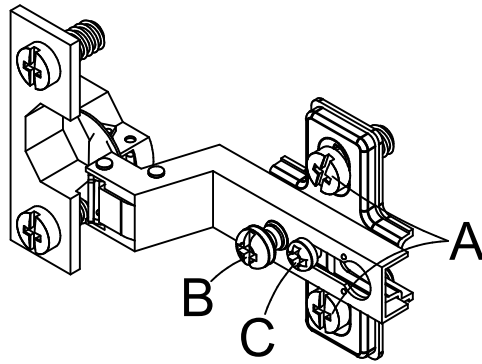
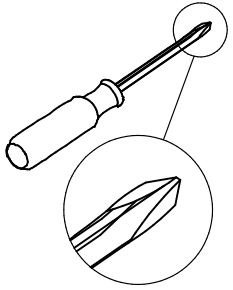

Loosen screw A
Adjust door.
Tighten screw A

Suelte el tornillo A
Acomode la puerta.
Ajuste el tornillo A

Défaites le vis A
Ajustez la porte.
Serrez le vis A

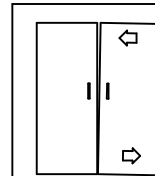

Loosen screw C
Turn screw B to
move door.
Tighten screw C

Suelte el tornillo C
Dé vuelta el tornillo B
para mover la puerta.
Ajuste el tornillo C

Défaites le vis C
Le vis du tour B
déplacer la porte.
Serrez le vis C

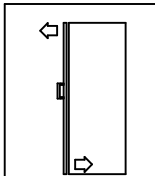

Loosen screw C
Adjust door.
Tighten screw C
*side view

Suelte el tornillo C
Acomode la puerta.
Ajuste el tornillo C
*la vista lateral

Défaites le vis C
Ajustez la porte.
Serrez le vis C
*le côté envisagent

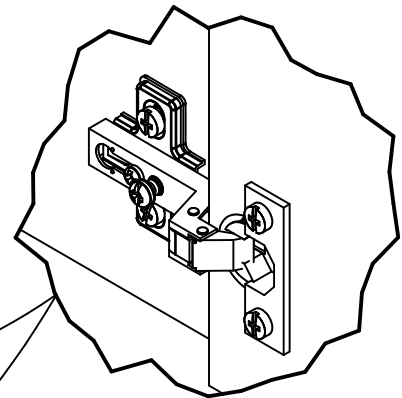
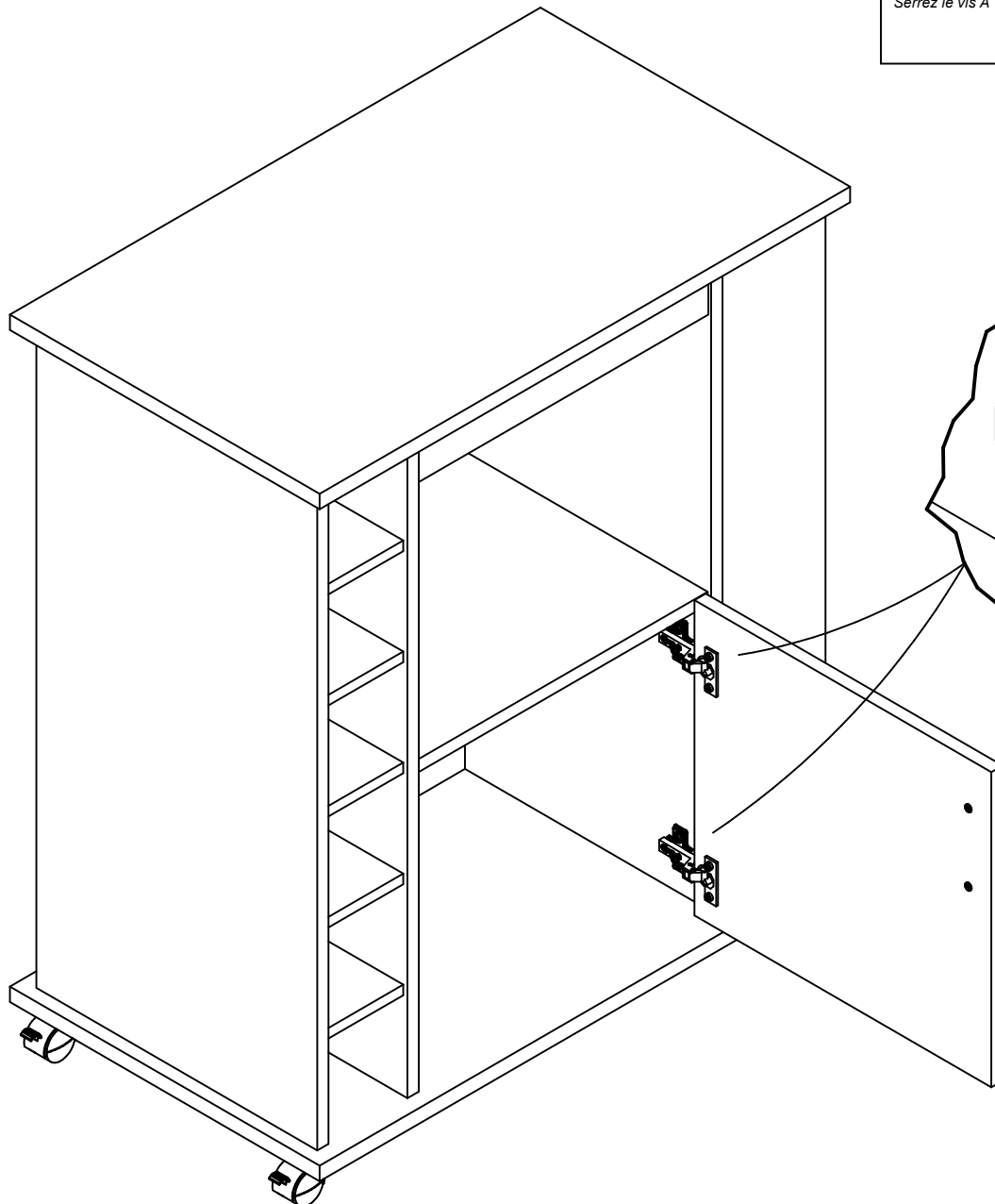

Maximum Loads

This unit has been designed to support the maximum loads shown. Exceeding these load limits could cause sagging, instability, product collapse, and/or serious injury.

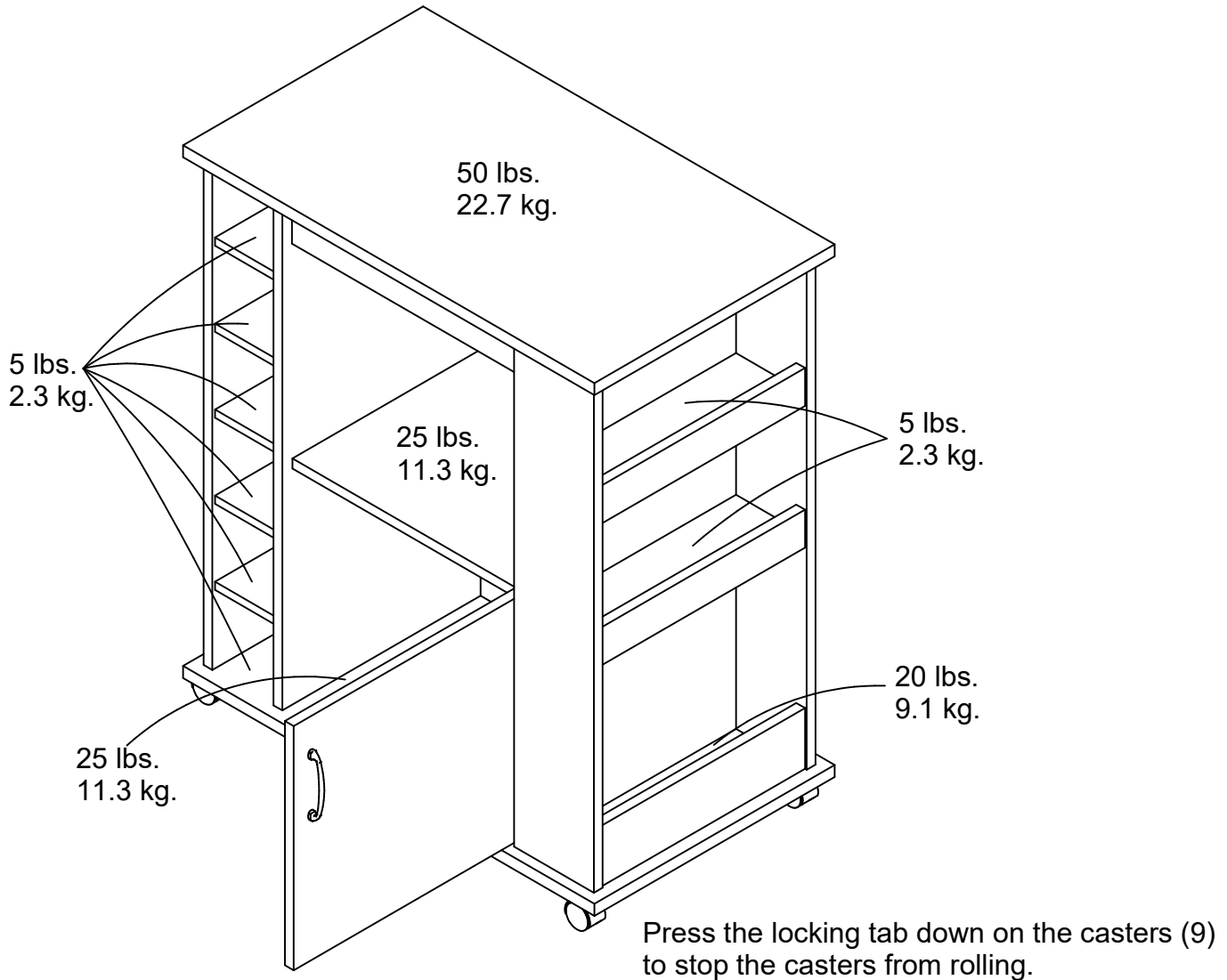

Certificate of Conformity

1. This certificate applies to the Dorel Home Furnishings, Inc. product identified by this instruction manual.
2. This certificate applies to compliance of this product with the CPSC Ban on Lead-Containing Paint (16 CFR 1303).
3. This product is distributed by: Dorel Home Furnishings, Inc.
410 East First Street South
Wright City, MO 63390
636-745-3351
4. Site of Manufacture: Tiffin, OH
5. See front page of instruction manual for date of manufacture.

Register your product to receive the following:



- * New trend details - sneak peek on what's new
- * Surveys - have a voice within our community
- * Exclusive deals and discount codes
- * Quick and easy replacement part service

To register your product, visit ameriwoodhome.com

5 Star Rating



Visit your local retailer's website, rate your purchased product and leave us some feedback!

We would like to extend a big "Thank You" to all of our customers for taking the time to assemble this Ameriwood Home product, and to give us your valuable feedback.

*Thank
You!*

Cubierta Delantera

Este libro de instrucciones contiene información **IMPORTANTE** de seguridad. Por favor lea y manténgalo para referencia en el futuro.

No Regrese este producto! Comuníquese con nuestro amigoso equipo de servicio al cliente para obtener ayuda.

Llámenos al: 1-800-489-3351 (Gratis) Lunes - Viernes 9am - 5pm CST

Visitar: www.ameriwoodhome.com

PRECAUCION

Este mueble puede volcarse y causar graves heridas y/o muerte.

Anclar el mueble a un poste de madera en la pared (si esto se requiere).

No Permita que los niños monten el mueble.

Mantenga los artículos más pesados en los cajones de abajo.

Consejos Útiles (página 2)

- Abra su artículo en el área donde usted planea utilizarlo para evitar levantar y moverlo menos
- Identificar, ordenar y contar las piezas antes de intentar ensamblar
- Las clavijas de compresión se golpean con un martillo
- Las diapositivas están marcadas con una R (derecha) y L (izquierda) para la colocación correcta
- Asegúrese de que siempre este el punto localizado en la parte superior de bloqueador de leva este volteado hacia borde exterior
- Utilizar todos los clavos para el panel de atrás y distribuirlos por igual
- El panel de atrás debe utilizarse para asegurarse de que la unidad quede fija y firme
- No use químicas fuertes ni limpiadores abrasivos en este artículo
- Nunca empuje, tire ni arrastre los muebles

Antes de Que Empieces (página 3)

- Lea cuidadosamente cada paso y siga el orden correcto
- Separar y contar todas sus piezas y hardware
- Dése suficiente espacio para el proceso de ensamble
- Tenga las siguientes herramientas: destornillador de cabeza plana, #2 cabeza Phillips
Destornillador y martillo
- Precaución: Si usa un taladro electrónico o un destornillador eléctrico para atornillar, por favor asegúrese que deje de atornillar cuando el tornillo este apretado. Fallar hacer esto puede causar barrer el tornillo.

Sistema de fijar el bloqueo de leva (página 3)

Esta sistema de fijar el bloqueo de leva sera usado en todo el proceso ensamble.

Página 19

Nota: Los rieles centro (M) se colocará entre el panel de la derecha (B) y partitin (C).

Página 22

Inserte las clavijas de madera (3) en los agujeros más grandes del extremo como se muestra.

Por favor nota, paneles E & F cubrirá el frente y atrás los bordes del panel derecho (B) cuando se instala.

Página 23

Primero inserte las ruedas (9).

Inserte las ruedas (9) en los agujeros como se muestra y prensa en más grande. El vástago de la ruedecilla inserta en los agujeros de estante inferior y mientras presiona insertará en los agujeros del extremo de paneles (A, E & F).

Utilizando los tornillos (6), fije la parte inferior (I) como se muestra.

Página 24

Inserte los soportes para estante (8) en los agujeros en el panel izquierdo (A) y partición (C) y coloque los estantes izquierdos (J) en su lugar.

Página 27

Esta unidad ha sido diseñada para soportar la carga máxima anotada. El exceder estos límites puede causar inestabilidad, colapsarse y/o causar serias lesiones.

Presione la lengüeta de bloqueo en las ruedas (9) para detener las ruedas de balanceo.

Página 28

Registre su producto para recibir lo siguiente:

- * Detalles de nuevas tendencias - Vistazo a lo nuevo
- * Encuestas - aloc su voz entre su comunidad
- * Códigos de ofertas y descuentos exclusivos
- * Fácil y rápido servicio de partes de remplace

Para registrar su producto, visite ameriwoodhome.com

Clasificación de 5 estrellas

Visite el sitio web de su tienda local, califique su comprado y denos sus comentarios!

Nos gustaría enviar un gran "Agradecimiento" a todos nuestros clientes por tomarse el tiempo de ensamblar este producto de Ameriwood Home, y por darnos sus valiosos comentarios.

Gracias

Couverture Avant

CE LIVRET D'INSTRUCTION CONTIENT DES INFORMATIONS **IMPORTANTES** SUR LA SÉCURITÉ. VEUILLEZ LIRE ET GARDER POUR UNE RÉFÉRENCE FUTURE

Ne retournez pas ce produit! Contactez notre équipe de service à la clientèle amicale d'abord pour obtenir de l'aide.

Appelez-nous: 1-800-489-3351 (sans frais) du Lundi au Vendredi de 9h à 17h Heure Centrale

Visitez: www.ameriwoodhome.com

ATTENTION

Le meuble peut basculer et causer des blessures graves ou la mort.

Ancrer le meuble à une planche murale dans le mur (si indiqué).

Ne laissez pas les enfants grimper sur le meuble.

Placez les articles lourds sur les étagères ou dans les tiroirs inférieurs.

Astuces Utiles (page 2)

-Ouvrez votre article dans la zone que vous prévoyez de le garder pour moins de levage lourd

-Identifier, trier et compter les pièces avant d'essayer d'assembler

-Les goujons de compression sont taraudés avec un Marteau

-Les glissières sont marquées d'un R (droit) et d'un L (gauche) pour un bon placement

-Assurez-vous toujours de faire face la pointe situé sur le haut de la Serrure de Came vers le bord extérieur

-Utiliser tous les clous fournis pour le panneau arrière et les répartir également

-Le panneau arrière doit être utilisé pour vous assurer que votre appareil est robuste

-N'utilisez pas de produits chimiques agressifs ou de nettoyeurs abrasifs sur cet appareil

-Ne jamais pousser, tirer, ou faire glisser votre meuble

Avant de Commencer (page 3)

-Lisez attentivement chaque étape et suivez le bon ordre

-Séparez et comptez toutes vos pièces et matériaux

-Donnez-vous suffisamment de place pour l'assemblage

-Avoir les outils suivants: tournevis à tête plate, #2 tournevis Phillips, et Marteau

-Attention: Si vous utilisez une perceuse électrique ou un tournevis électrique pour visser, veillez à ralentir et arrêter lorsque la vis est bien serrée. Le non-respect de cette consigne peut endommager la vis.

Système de Fixation de Came (page 3)

Ce Système de Fixation de Came sera utilisé tout au long de l'assemblage

Page 19

Remarque : Les rails de centre (M) seront positionnés entre le panneau de droite (B) et partitin (C).

Page 22

Insérez les goujons en bois (3) dans les plus grands trous de fin, comme illustré.

S'il vous plaît note, panneaux E & F couvrira l'avant et arrière bords du panneau droit (B) lors de l'installation.

Page 23

Insérez les roulettes (9) en premier.

Insérez les roulettes (9) dans les plus gros trous comme indiqué et presse dans. La tige à roulette va insérer dans les trous du plateau bas et tout en enfonçant insèrera dans les trous d'angle en panneaux (A, E & F).

À l'aide de vis (6), accrocher le fond (I) comme indiqué.

Page 24

Insérer les supports de tablette (8) dans les trous dans le panneau de gauche (A) et de la partition (C) et fixer les étagères de gauche (J) en place.

Page 27

Ce meuble a été conçu pour supporter les charges maximales indiquées. En excédant ces limites de charge, le meuble pourrait devenir instable, s'effondrer, et/ou causer des blessures graves.

Appuyez sur la languette de verrouillage vers le bas sur les roulettes (9) pour arrêter les roulettes de rouler.

Page 28

Enregistrez votre produit pour recevoir les éléments suivantes:

- * Détails sur les nouvelles tendances - un aperçu sur les nouveautés
- * Sondages - avoir une voix au sein de notre communauté
- * Offres exclusives et codes promo
- * Service de pièces de rechange rapide et facile

Pour enregistrer votre produit, visitez ameriwoodhome.com

5 Étoiles

Visitez le site Web de votre détaillant local, évaluez votre produit acheté et laissez-nous quelques commentaires !

Nous tenons à offrir un grand "Merci" à tous nos clients pour avoir pris le temps d'assembler ce produit "Ameriwood Home", et de nous donner vos commentaires précieux.

Merci